

MEMS digital output motion sensor

Ultra-low-power high performance 3-axes “DSC-XYZ” accelerometer

Key Features

- Supply voltage, 1.62V to 3.6V
- For 2x2x0.9 mm LGA-12 package
- User selectable range, $\pm 2g$, $\pm 4g$, $\pm 8g$, $\pm 16g$
- User selectable data output rate
- Digital I²C/SPI output interface
- 16 bit resolution
- Ultra-low power consumption
- Embedded 32-level FIFO
- Internal step counter
- 2 Programmable interrupt generators with independent function for motion detection
- Factory programmable offset and sensitivity
- RoHS compliant

Applications

- User interface for mobile phone and PMP
- Display orientation
- Gesture recognition
- Active/Inactive monitoring
- Free-fall detection
- Flat detection
- Tilt on wrist detection
- Double/single Click recognition
- Power management
- Vibration monitoring
- Step counter
- Tilt
- Significant motion
- Self-test function



Product Overview

The da618G sensor is ultra-low power high performance capacitive three-axis linear accelerometer developed by micro-machined technology. The device is available in a 2x2x0.9mm land grid array (LGA) and it is guaranteed to operate over an extended temperature range from -40°C to $+85^{\circ}\text{C}$.

The sensor element is fabricated by single crystal silicon with DRIE process and is protected by hermetically sealed silicon cap from the environment.

The device features user selectable full scale of $\pm 2g$ / $\pm 4g$ / $\pm 8g$ / $\pm 16g$ measurement range with data output rate from 1Hz to 1600Hz with signal condition, temperature compensation, motion detection, step counter and step detection along with significant motion detection embedded.

The da618G has an integrated 32-level first-in, first-out (FIFO) buffer allowing the user to store data in order to limit intervention by the host processor.

Two independent and flexible interrupts provided greatly simplify the algorithm for various motion status detections. Standard I²C and SPI interfaces are used to communicate with the chip.

Content

- 1. Block diagram and pin description 9
 - 1.1. Block diagram 9
 - 1.2. Pin description 9
- 2. Mechanical and electrical specifications 11
 - 2.1. Mechanical characteristics 11
 - 2.2. Electrical characteristics 12
 - 2.3. Absolute maximum ratings 12
- 3. Communication interface 13
 - 3.1. Communication interface Electrical specification 13
 - 3.1.1. SPI Electrical specification 13
 - 3.1.2. I2C Electrical specification 14
 - 3.2. Digital interface operation 15
 - 3.2.1. SPI Operation 15
 - 3.2.2. I2C Operation 16
- 4. Terminology and functionality 18
 - 4.1. Terminology 18
 - 4.1.1. Sensitivity 18
 - 4.1.2. Zero-g level 18
 - 4.2. Functionality 18
 - 4.2.1. Power mode 18
 - 4.2.2. Sensor data 19
 - 4.2.3. Factory calibration 20
 - 4.2.4. Self-test 20
 - 4.3. Interrupt controller 21
 - 4.3.1. General features 21
 - 4.3.2. Mapping 22
 - 4.3.3. Electrical behavior (INT1/INT2 to open-drain or push-pull) 22
 - 4.3.4. New data interrupt 22
 - 4.3.5. Active/Inactive detection 22
 - 4.3.6. Tap detection 23
 - 4.3.7. Orientation recognition 25
 - 4.3.8. Frefall interrupt 26
- 5. Digital blocks 27
 - 5.1. FIFO 27
 - 5.1.1. Bypass Mode 27
 - 5.1.2. FIFO Mode 27
 - 5.1.3. Stream Mode 27
 - 5.1.4. Trigger Mode 27
 - 5.1.5. Retrieving Data from FIFO 27
 - 5.2. Embedded functions 28
 - 5.2.1. Step counter 28

5.2.2.	Step detector	28
5.2.3.	Significant motion	28
5.2.4.	Tilt	28
5.2.5.	Flat detection	29
5.2.6.	Tilt on wrist	29
6.	Application hints	32
7.	Register mapping.....	32
8.	Registers description	35
8.1.	SPI_CONFIG (00H).....	35
8.2.	CHIP_ID (01H)	35
8.3.	ACC_X_LSB (02H), ACC_X_MSB (03H)	35
8.4.	ACC_Y_LSB (04H), ACC_Y_MSB (05H)	36
8.5.	ACC_Z_LSB (06H), ACC_Z_MSB (07H)	36
8.6.	FIFO_STATUS (08H)	36
8.7.	MOTION_FLAG1 (09H).....	37
8.8.	MOTION_FLAG2 (0AH).....	37
8.9.	TAP_ACTIVE_STATUS (0BH).....	38
8.10.	ORIENT_STATUS (0CH).....	39
8.11.	STEPS_MSB (0DH), STEPS_LSB (0EH).....	39
8.12.	RESOLUTION_RANGE (0FH)	40
8.13.	MODE_ODR (10H).....	41
8.14.	MODE_AXIS (11H).....	42
8.15.	SWAP_POLARITY (12H)	42
8.16.	FIFO_CTRL (14H).....	43
8.17.	INT_SET0 (15H).....	43
8.18.	INT_SET1 (16H).....	44
8.19.	INT_SET2 (17H).....	45
8.20.	INT_MAP1 (19H)	46
8.21.	INT_MAP2 (1AH)	46
8.22.	INT_MAP3 (1BH)	47
8.23.	INT_MAP4(1CH)	47
8.24.	INT_CONFIG (20H).....	48
8.25.	INT_LATCH (21H).....	49
8.26.	FREEFALL_DUR (22H).....	50
8.27.	FREEFALL_THS (23H)	50
8.28.	FREEFALL_HYST (24H).....	50
8.29.	FLAT_TH(25H).....	51
8.30.	TAP_QUIET(29H)	51
8.31.	TAP_DUR (2AH).....	52
8.32.	TAP_THS (2BH).....	53
8.33.	ORIENT_HYST (2CH).....	54
8.34.	Z_BLOCK (2DH).....	54
8.35.	RESET_STEP (2EH).....	54
8.36.	STEP_FILTER (33H).....	55

- 8.37. SM_THRESHOLD (34H).....55
- 8.38. ACTIVE_DUR (38H)55
- 8.39. ACTIVE_X_THS (39H)56
- 8.40. ACTIVE_Y_THS (3AH).....56
- 8.41. ACTIVE_Z_THS (3BH)56
- 9. Package information.....57
 - 9.1. Outline dimensions.....57
 - 9.2. Landing pattern recommendation.....58
 - 9.3. Soldering guidelines59
 - 9.4. Tape and reel specification61
- 10. Revision history.....62

List of tables

Table 1.Pin description	10
Table 2.Mechanical characteristic	11
Table 3.Electrical characteristics.....	12
Table 4.Absolute maximum ratings	12
Table 5.Electrical specification of the SPI interface pins	13
Table 6.Electrical specification of the I2C interface pins	14
Table 7.Mapping of the interface pins.....	15
Table 8.W1 and W0 settings	16
Table 9.I2C Address	16
Table 10.SAD+Read/Write patterns.....	16
Table 11.Transfer when master is writing one byte to slave.....	17
Table 12.Transfer when master is writing multiple bytes to slave.....	17
Table 13.Transfer when master is receiving (reading) one byte of data from slave	17
Table 14.Transfer when master is receiving (reading) multiple bytes of data from slave	17
Table 15.Interrupt mode selection	21
Table 16.meaning of ‘orient’ bits in symmetric mode.....	25
Table 17.meaning of ‘orient’ bits in high-asymmetric mode.....	25
Table 18.meaning of ‘orient’ bits in low-asymmetric mode.....	26
Table 19.blocking conditions for orientation recognition	26
Table 20.Register address map.....	33
Table 21.SPI_CONFIG register.....	35
Table 22.SPI_CONFIG description	35
Table 23.CHIP_ID register	35
Table 24.ACC_X_LSB register	35
Table 25.ACC_X_MSB register	35
Table 26.ACC_Y_LSB register	36
Table 27.ACC_Y_MSB register	36
Table 28.ACC_Z_LSB register	36
Table 29.ACC_Z_MSB register	36
Table 30.FIFO_STATUS register	36
Table 31. FIFO_STATUS register description	36
Table 32.MOTION_FLAG1 register.....	37
Table 33.MOTION_FLAG1 register description.....	37
Table 34.MOTION_FLAG2 register.....	37
Table 35.MOTION_FLAG2 register description.....	37
Table 36.TAP_ACTIVE_STATUS register	38
Table 37.TAP_ACTIVE_STATUS register description	38
Table 38.ORIENT_STATUS register.....	39
Table 39.ORIENT_STATUS register description.....	39
Table 40.STEPS_MSB register	39
Table 41.STEPS_MSB register description	39
Table 42.STEPS_LSB register	39

Table 43.STEPS_LSB register description39

Table 44.RESOLUTION_RANGE register40

Table 45.RESOLUTION_RANGE register description40

Table 46.MODE_ODR register41

Table 47.MODE_ODR register description41

Table 48.MODE_AXIS register.....42

Table 49.MODE_AXIS register description.....42

Table 50.SWAP_POLARITY register42

Table 51.SWAP_POLARITY register description.....42

Table 52.FIFO_CTRL register43

Table 53.FIFO_CTRL register description43

Table 54.INT_SET0 register43

Table 55.INT_SET0 register description43

Table 56.INT_SET1 register44

Table 57.INT_SET1 register description44

Table 58.INT_SET2 register45

Table 59.INT_SET2 register description45

Table 60.INT_MAP1 register46

Table 61.INT_MAP1 register description46

Table 62.INT_MAP2 register46

Table 63.INT_MAP2 register description46

Table 64.INT_MAP3 register47

Table 65.INT_MAP3 register description47

Table 66.INT_MAP4 register47

Table 67.INT_MAP3 register description47

Table 68.INT_CONFIG register48

Table 69.INT_CONFIG register description48

Table 70.INT_LATCH register49

Table 71.INT_LATCH register description49

Table 72.FREEFALL_DUR register50

Table 73.FREEFALL_DUR register description50

Table 74.FREEFALL_THS register.....50

Table 75.FREEFALL_THS register description.....50

Table 76.FREEFALL_HYST register.....50

Table 77.FREEFALL_HYST register description.....50

Table 78.FLAT_TH register51

Table 79.FLAT_TH register description51

Table 80.TAP_QUIET register51

Table 81.TAP_QUIET register description.....51

Table 82.TAP_DUR register.....52

Table 83.TAP_DUR register description.....52

Table 84.TAP_THS register.....53

Table 85.TAP_THS register description.....53

Table 86.ORIENT_HYST register.....54

Table 87. ORIENT_HYST register description.....54

Table 88. Z_BLOCK register.....54

Table 89. Z_BLOCK register description.....54

Table 90. RESET_STEP register.....54

Table 91. RESET_STEP register description.....54

Table 92. STEP_FILTER register.....55

Table 93. STEP_FILTER register description.....55

Table 94. SM_THRESHOLD register.....55

Table 95. SM_THRESHOLD register description.....55

Table 96. ACTIVE_DUR register.....55

Table 97. ACTIVE_DUR register description.....55

Table 98. ACTIVE_X_THS register.....56

Table 99. ACTIVE_X_THS register description.....56

Table 100. ACTIVE_Y_THS register.....56

Table 101. ACTIVE_Y_THS register description.....56

Table 102. ACTIVE_Z_THS register.....56

Table 103. ACTIVE_Z_THS register description.....56

Table 106. Document revision history.....62

List of figures

Figure 1 Block Diagram.....	9
Figure 2 Pin description.....	9
Figure 3 SPI slave timing diagram.....	13
Figure 4 I2C Slave timing diagram.....	14
Figure 5 Instruction Phase Bit Field.....	15
Figure 6 MSB First and LSB First Instruction and Data Phases.....	16
Figure 7 I2C Protocol.....	17
Figure 8 Power mode.....	18
Figure 9 Interrupt mode.....	22
Figure 10 Timing of tap detection.....	24
Figure 11 Definition of vector components.....	25
Figure 12 Valid position for Tilt on Wrist.....	29
Figure 13 da618G I2C electrical connect.....	32
Figure 14 da618G SPI electrical connect.....	32
Figure 15 12Pin LGA Mechanical data and package dimensions.....	57
Figure 16 landing patterns; dimensions in mm.....	58
Figure 17 Soldering profile.....	60
Figure 18 Tape and reel dimension in mm.....	61

1. Block diagram and pin description

1.1. Block diagram

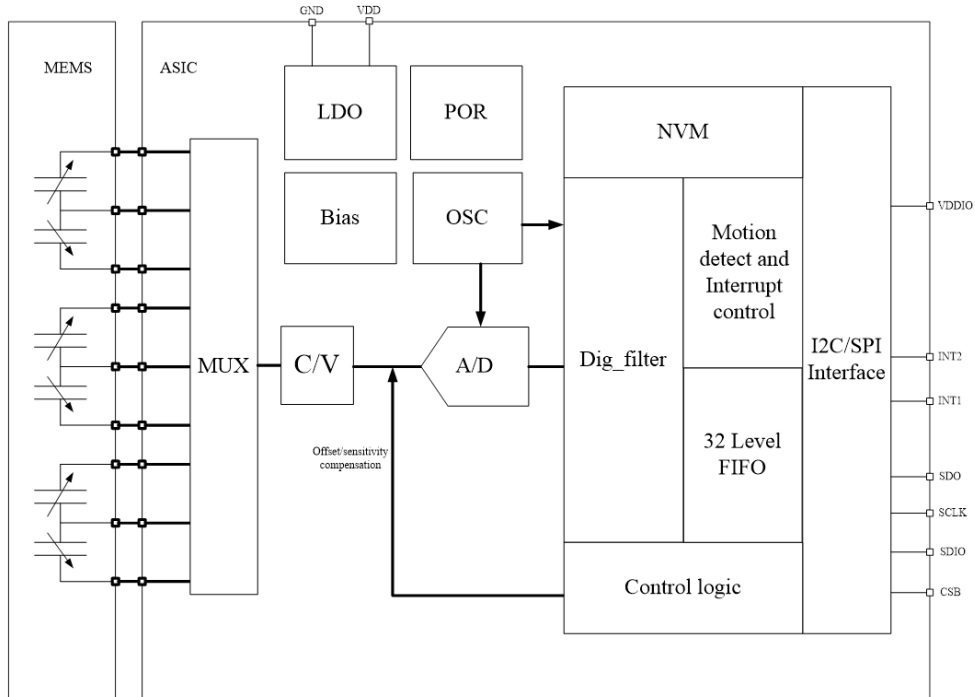

Figure 1 Block Diagram

1.2. Pin description

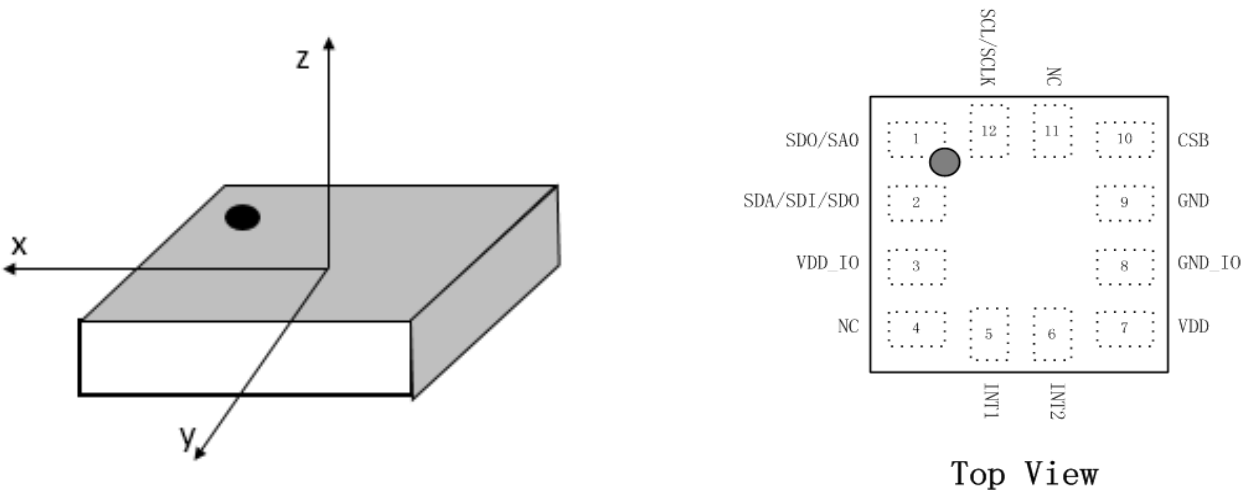

Figure 2 Pin description

Table 1.Pin description

Pin#	Name	I/O Type	Function
1	SDO SA0	Digital out Digital in	SPI(4-wire mode) serial data output (SDO) I2C less significant bit of the device address (SA0) When using the I2C communication: SA0 must be connected to VDDIO for I2C Address 0x27 SA0 must be connected to GND for I2C Address 0x26
2	SDA SDI SDO	Digital in/out	I2C serial data input/output(SDA) SPI(4-wire mode) serial data input (SDI) 3-wire interface serial data input/output (SDO)
3	VDD_IO	Supply	Power supply for I/O pins
4	NC	--	NO internal connection
5	INT1	Digital out	Interrupt pin1
6	INT2	Digital out	Interrupt pin2
7	VDD	Supply	Power supply
8	GND_IO	Ground	Ground supply for I/O pins
9	GND	Ground	Ground supply
10	CSB	Digital in	Chip select for SPI When using the I2C communication, CSB pin must be connected to VDDIO
11	NC	--	NO internal connection
12	SCL SCLK	Digital in	I2C serial clock (SCL) SPI serial clock (SCLK)

NOTE:

1. NC- NO internal connection.

2. Mechanical and electrical specifications

2.1. Mechanical characteristics

VDD = 2.5 V, T = 25 °C unless otherwise noted.

Table 2. Mechanical characteristic

Symbol	Parameter	Test conditions	Min	Type	Max	Unit
FS	Measurement range	FS bit set to 00		±2		g
		FS bit set to 01		±4		g
		FS bit set to 10		±8		g
		FS bit set to 11		±16		g
So	Sensitivity	FS = 2g		16384		LSB/g
		FS = 4g		8192		LSB/g
		FS = 8g		4096		LSB/g
		FS = 16g		2048		LSB/g
TCSO	Sensitivity change vs. temperature	FS = 2g		±0.01		%/°C
Tyoff	Typical zero-g level offset accuracy			±70		mg
Tcoff	Zero-g level change vs. temperature	Max delta from 25°C		±0.6		mg/°C
Noise	XYZ RMS noise	FS = 16g Performance mode, 400Hz		1.5		mg
N _{DEN}	Noise density	FS = 16g Performance mode, 400Hz		120		µg/√Hz
NL	Nonlinearity	FS = 2g		±0.5		%FS
ODR _{PERF}	Output data rate	Performance Mode	0.8		1600	Hz
ODR _{0.8}	Output data rate and BW in Performance mode	3dB cutoff frequency of the accelerometer according to ODR		0.31		Hz
ODR _{1.6}				0.62		Hz
ODR _{3.125}				1.25		Hz
ODR _{6.25}				2.5		Hz
ODR _{12.5}				5		Hz
ODR ₂₅				10		Hz
ODR ₅₀				20		Hz
ODR ₁₀₀				40		Hz
ODR ₂₀₀				80		Hz
ODR ₄₀₀				160		Hz
ODR ₈₀₀				320		Hz
ODR ₁₆₀₀				640		Hz
ODR _{LPM}			Output data rate	Low power Mode	0.8	
Top	Operation temperature range		-40		85	°C

2.2. Electrical characteristics

Vdd = 2.5 V, T = 25 °C unless otherwise noted

Table 3. Electrical characteristics

Symbol	Parameter	Test conditions	Min	Typ.	Max	Unit
VDD	Supply voltage		1.62	2.5	3.6	V
VDD_IO	I/O Pins supply voltage		1.62		3.6	V
IDD_PERF	current consumption in performace mode	Top=25°C, ODR=1600Hz,		180		uA
IDD_LPM	current consumption in low power mode	Top=25°C, ODR=100Hz,		12		uA
IDD_SM	current consumption in suspend mode	Top=25°C		1		uA
TVDD	VDD&VDDIO power up time				100	ms
VIH	Digital high level input voltage	SPI&I2C	0.7*Vdd_IO			V
VIL	Digital low level input voltage	SPI&I2C			0.3*Vdd_IO	V
VOH	high level output voltage		0.9*Vdd_IO			V
VOL	Low level output voltage				0.1*Vdd_IO	V
TWU	Wake-up time	From stand-by		1		ms
TSU	Start-up time	From power off		3		ms
PSRR	Power Supply Rejection Rate	Top=25°C			20	mg/V

2.3. Absolute maximum ratings

Stresses below those listed as “absolute maximum ratings” may cause permanent damage to the device. This is a stress rating only and functional operation of the device under these conditions is not implied. Exposure to maximum rating conditions for extended periods may affect device reliability.

Table 4. Absolute maximum ratings

Parameter	Test conditions	Min	Max	Unit
Storage Temperature		-45	125	°C
Supply Voltage VDD	Supply pins	-0.3	4.25	V
Supply Voltage VDD_IO	Logic pins	-0.3	Vdd_IO+0.3	V
ESD Rating	HMB,R=1.5k,C=100pF		±2	kV
Mechanical Shock	Duration<200us		10,000	g

Note: Supply voltage on any pin should never exceed 4.25V



This is a mechanical shock sensitive device, improper handling can cause permanent damages to the part.



This is an ESD sensitive device, improper handling can cause permanent damages to the part.

3. Communication interface

3.1. Communication interface Electrical specification

3.1.1. SPI Electrical specification

Table 5. Electrical specification of the SPI interface pins

Symbol	Parameter	Condition	Min	Max	Unit
f _{sclk}	Clock frequency	Max load on SDIO or SDO = 25pF		10	MHz
t _{SCKL}	SLCK low pulse		20		ns
t _{SCKH}	SLCK high pulse		20		ns
t _{SDI_setup}	SDI setup time		20		ns
t _{SDI_hold}	SDI hold time		20		ns
t _{SDO_OD}	SDO/SDI output delay	Load = 25pF		30	ns
		Load = 250pF		40	ns
t _{CSB_setup}	CSB setup time		20		ns
t _{CSB_hold}	CSB hold time		40		ns

The figure below shows the definition of the SPI timing given in the above table:

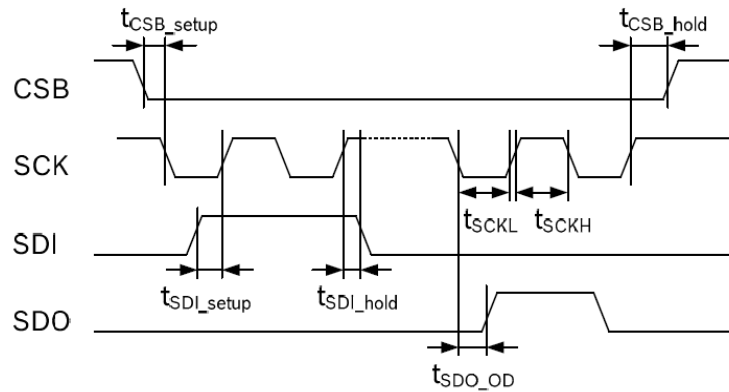

Figure 3 SPI slave timing diagram

3.1.2.I2C Electrical specification

Table 6.Electrical specification of the I2C interface pins

Symbol	Parameter	Min	Max	Unit
f _{scl}	Clock frequency		400	kHz
t _{LOW}	SCL low pulse	1.3		us
t _{HIGH}	SCL high pulse	0.6		us
t _{SUDAT}	SDA setup time	0.1		us
t _{HDDAT}	SDA hold time	0.0		us
t _{SUSTA}	Setup Time for a repeated start condition	0.6		us
t _{HDSTA}	Hold time for a start condition	0.6		us
t _{SUSTO}	Setup Time for a stop condition	0.6		us
t _{BUF}	Time before a new transmission can start	1.3		us

The figure below shows the definition of the I2C timing given in the above table:

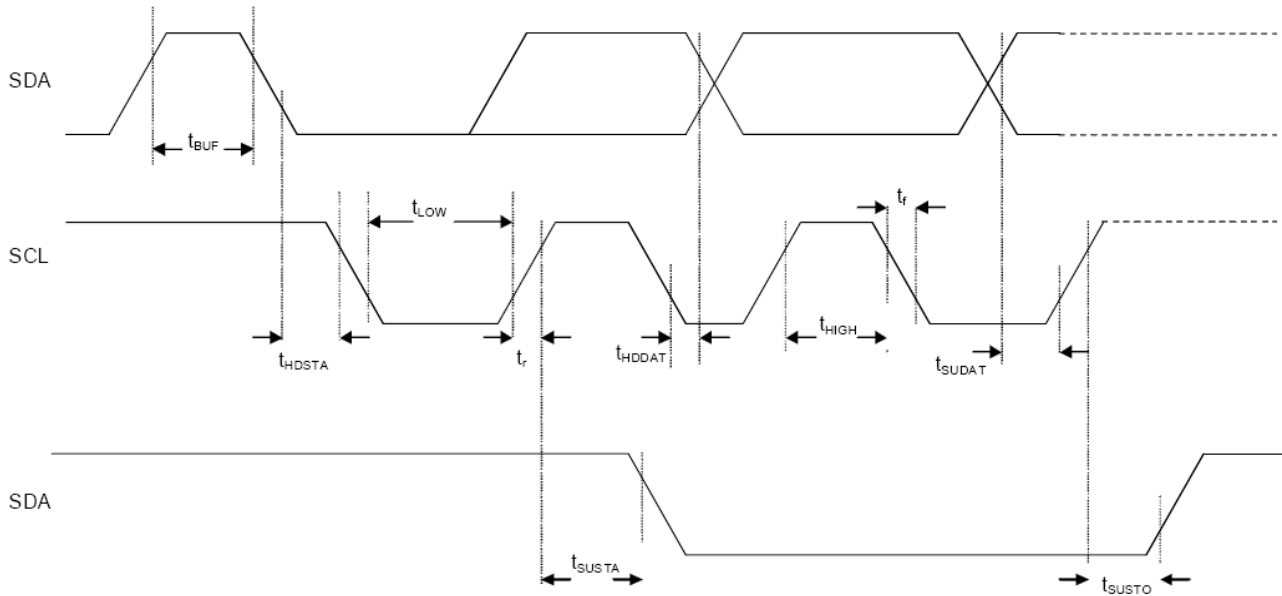

Figure 4 I2C Slave timing diagram

3.2. Digital interface operation

The da618G supports two serial digital interface protocols for communications as slave with a host device: SPI and I2C. The active interface is selected by the state of the pin CS, 0 selects SPI and 1 selects I2C. By default, SPI operates in 4-wire mode and it can be re-configured by writing 0 to bit ‘SDO_active’ to work in 3-wire mode. Both interfaces share the same pins. The mapping for each interface is given in the following table:

Table 7. Mapping of the interface pins

PIN name	I2C	SPI
SCL/SCLK	Serial clock	Serial clock
SDA/SDI	Serial Data	Data input (4-wire mode). Data input/output (3-wire mode)
SA0/SDO	Used to set LSB of I2C address	Data output (4-wire mode)
CSB	IIC interface select, must keep high	Chip select

3.2.1. SPI Operation

The da618G just support SPI mode ‘00’(CPHA=CPOL=0). The falling edge of CSB, in conjunction with the rising edge of SCLK, determines the start of framing. Once the beginning of the frame has been determined, timing is straightforward. The first phase of the transfer is the instruction phase, which consists of 16 bits followed by data that can be of variable lengths in multiples of 8 bits. If the device is configured with CSB tied low, framing begins with the first rising edge of SCLK.

The instruction phase is the first 16 bits transmitted. As shown in the following figure, the instruction phase is divided into a number of bit fields.

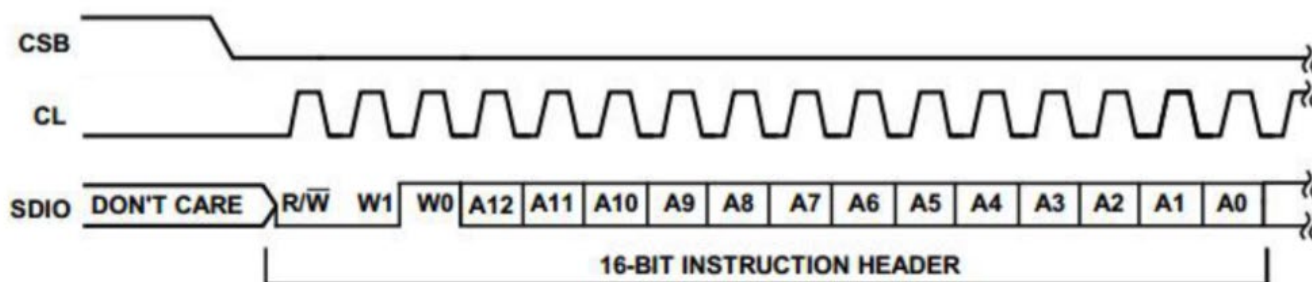

Figure 5 Instruction Phase Bit Field

The first bit in the stream is the read/write indicator bit (R/W). When this bit is high, a read is being requested, otherwise indicates it is a write operation.

W1 and W0 represent the number of data bytes to transfer for either read or write as shown in the following table (W1 and W0 setting table). If the number of bytes to transfer is three or less (00, 01, or 10), CSB can stall high on byte boundaries. Stalling on a non-byte boundary terminates the communications cycle. If these bits are 11, data can be transferred until CSB transitions high. CSB is not allowed to stall during the streaming process.

The remaining 13 bits represent the starting address of the data sent. If more than one word is being sent, sequential addressing is used, starting with the one specified, and it either increments (LSB first) or decrements (MSB first) based on the mode setting.

Table 8.W1 and W0 settings

W1:W0	Action	CSB stalling
00	1 byte of data can be transferred.	Optional
01	2 bytes of data can be transferred.	Optional
10	3 bytes of data can be transferred.	Optional
11	4 or more bytes of data can be transferred. CSB must be held low for entire sequence; otherwise, the cycle is terminated.	No

Data follows the instruction phase. The amount of data sent is determined by the word length (Bit W0 and Bit W1). This can be one or more bytes of data. All data is composed of 8-bit words.

Data can be sent in either MSB-first mode or LSB-first mode (by setting 'LSB_first' bit). On power up, MSB-first mode is the default. This can be changed by programming the configuration register. In MSB-first mode, the serial exchange starts with the highest-order bit and ends with the LSB. In LSB-first mode, the order is reversed. The detail is shown in the below figure.

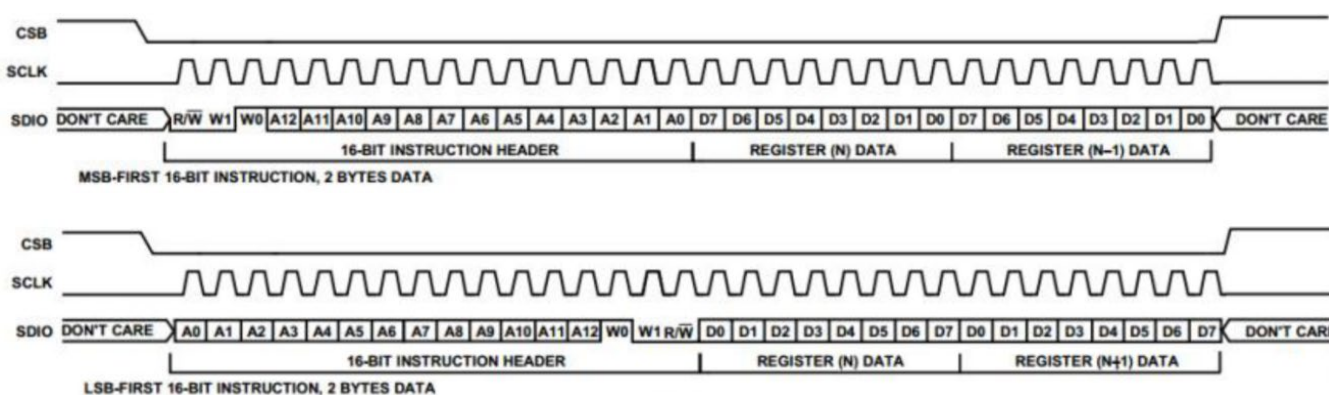

Figure 6 MSB First and LSB First Instruction and Data Phases

Register bit 'SDO_active' is responsible for activating SDO on devices. If this bit is cleared, then SDO is inactive and read data is routed to the SDI pin. If this bit is set, read data is placed on the SDO pin. The default for this bit is high, making SDO active.

3.2.2.I2C Operation

I2C bus uses SCL and SDA as signal lines. Both lines are connected to VDDIO externally via pull-up resistors so that they are pulled high when the bus is free. The I2C device address of da618G is shown below. The LSB bit of the 7bits device address is configured via SA0 pin.

Table 9.I2C Address

SAD6	SAD5	SAD4	SAD3	SAD2	SAD1	SAD0	W/R
0	1	0	0	1	1	SA0	0/1

Table 10.SAD+Read/Write patterns

Command	SAD[6:1]	SAD[0]=SA0	R/W	SAD+R/W
Read	010011	0	1	01001101(4dh)
Write	010011	0	0	01001100(4ch)
Read	010011	1	1	01001111(4fh)
Write	010011	1	0	01001110(4eh)

The I2C interface protocol has special bus signal conditions. Start (S), stop (P) and binary data conditions are shown below. At start condition, SCL is high and SDA has a falling edge. Then the slave address is sent. After the 7 address bits, the direction control bit R/W selects the read or write operation. When a slave device recognizes that it is being addressed, it should acknowledge by pulling SDA low in the ninth SCL cycle (ACK) cycle.

At stop condition, SCL is also high, but SDA has a rising edge. Data must be held stable at SDA when SCL is high. Data can change value at SDA only when SCL is low.

In order to prevent the I2C slave of the device to lock-up the I2C bus, a watchdog timer (WDT) is implemented. The WDT observes internal I2C signals and resets the I2C interface if the bus is locked-up by the sensor. The activity and the timer period of the WDT can be configured through the bits “wdt_en” and “wdt_time” of “RESOLUTION_RANGE” (0fH) register.

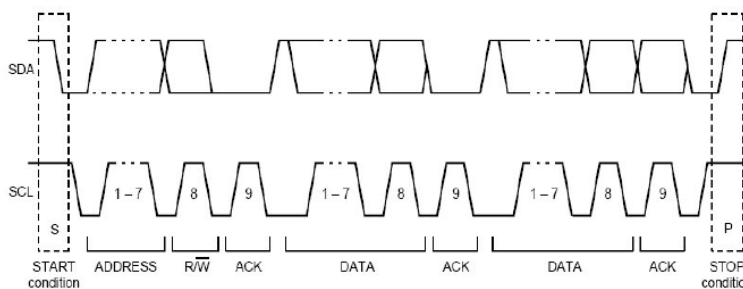

Figure 7 I2C Protocol

Table 11. Transfer when master is writing one byte to slave

Master	S	SAD+W		SUB		DATA		P
Slave			SAK		SAK		SAK	

Table 12. Transfer when master is writing multiple bytes to slave

Master	S	SAD+W		SUB		DATA		DATA		P
Slave			SAK		SAK		SAK		SAK	

Table 13. Transfer when master is receiving (reading) one byte of data from slave

Master	S	SAD+W		SUB		SR	SAD+R			NMASK	P
Slave			SAK		SAK			SAK	DATA		

Table 14. Transfer when master is receiving (reading) multiple bytes of data from slave

Master	S	SAD+W		SUB		SR	SAD+R			MAK		MAK		NMASK	P
Slave			SAK		SAK			SAK	DATA		DATA		DATA		

Note:

Symbol	Symbol explain	Symbol	Symbol explain
SAD	slave address	SAK	slave acknowledge
W	write	MAK	master acknowledge
R	read	NMASK	no master acknowledge
S	start	SUB	Sub-address(register address)
P	stop	DATA	Read or write data
SR	start		

4. Terminology and functionality

4.1. Terminology

4.1.1. Sensitivity

Sensitivity describes the gain of the sensor and can be determined e.g. by applying 1 g acceleration to it. As the sensor can measure DC accelerations this can be done easily by pointing the axis of interest towards the center of the earth, noting the output value, rotating the sensor by 180 degrees (pointing to the sky) and noting the output value again. By doing so, ± 1 g acceleration is applied to the sensor. Subtract the larger output value from the smaller one, and dividing the result by 2, leads to the actual sensitivity of the sensor. This value changes very little over temperature and also time. The sensitivity tolerance describes the range of sensitivities of a large population of sensors.

4.1.2. Zero-g level

Zero-g level offset (TyOff) describes the deviation of an actual output signal from the ideal output signal if no acceleration is present. A sensor in a steady state on a horizontal surface measure 0 g in X axis and 0 g in Y axis whereas the Z axis measure 1 g. The output is ideally in the middle of the dynamic range of the sensor (content of output data registers are 00h, data expressed as 2's complement number). A deviation from ideal value in this case is called Zero-g offset. Offset is to some extent a result of stress to MEMS sensor and therefore the offset can slightly change after mounting the sensor onto a printed circuit board or exposing it to extensive mechanical stress. Offset changes little over temperature; see "Zero-g level change vs. temperature". The Zero-g level tolerance (TyOff) describes the standard deviation of the range of Zero-g levels of a population of sensors.

4.2. Functionality

4.2.1. Power mode

The da618G has three different power modes. Besides performance mode, which represents the fully operational state of the device, there are two special energy saving modes: low-power mode and suspend mode.

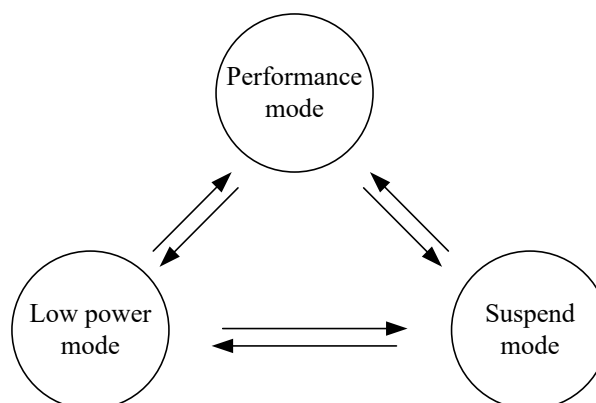

Figure 8 Power mode

In performance mode, all parts of the electronic circuit are held powered-up and data acquisition is performed continuously. Performance mode is entered by writing ‘1’ to the ‘perf_mode’ bits.

In suspend mode, the whole analog part, including the oscillator, Ana LDO, Dig LDO and Drive Buffer are all powered down, no data acquisition is performed and the only supported operation is to read/write the registers. Suspend mode is entered by writing ‘1’ to the ‘power_off’ bits.

In low power mode, the device is periodically switching between a sleep phase and a wake-up phase. The wake-up phase essentially corresponding to operation in performance mode with complete power-up of the circuitry. During the sleep phase the analog part except the oscillator is powered down.

During the wake-up phase, if a enabled interrupt is detected, the device stays in the wake-up phase as long as the interrupt condition endures (non-latched interrupt), or until the latch time expires (temporary interrupt), or until the interrupt is reset (latched interrupt). If no interrupt detected, the device enters the sleep phase.

The mode config is according to the following table.

Mode	Power_off	Perf_mode
Performance mode	0	1
Low power mode	0	0
Suspend mode	1	X

4.2.2.Sensor data

Acceleration Data:

The width of acceleration data is 16bits given in two’s complement representation. The 16bits for each axis are split into an MSB part (one byte containing bits 15 to 8) and an LSB lower part (one byte containing bits 7 to 0).

BW:

The bandwidth of the acceleration data is always 0.4x of the update rate according to the following table.

ODR[Hz]	0.8	1.6	3.125	6.25	12.5	25	50	100	200	400	800	1600
3dB cutoff frequency[Hz]	0.31	0.62	1.25	2.5	5	10	20	40	80	160	320	640

Filter setting:

The accelerometer digital filter can be configured through the register (0x10) ‘Perf_level[2:0]’bits. It can be used only in performance mode (perf_mode=1). The filter setting have four levels:level0、level1、level2、level3. If the higher filter level is selected, the better the filter effect will be.

OSR setting:

The OSR setting can be configured through the register (0x10) ‘Perf_level[2:0]’bits. It can be used only in low power mode (perf_mode=0). It means the average number of samples in an ODR cycle.

The following table shows the configuration relationship between ODR and OSR.

ODR	OSR @low-power mode
1600Hz(1011)	1x
800Hz (1010)	1x,2x
400Hz (1001)	1x,2x,4x
200Hz (1000)	1x,2x,4x,8x

100Hz (0111)	1x,2x,4x,8x,16x
50Hz (0110)	1x,2x,4x,8x,16x,32x
25Hz (0101)	1x,2x,4x,8x,16x,32x,64x
12.5Hz (0100)	1x,2x,4x,8x,16x,32x,64x,128x
6.25Hz (0011)	1x,2x,4x,8x,16x,32x,64x,128x
3.125Hz (0010)	1x,2x,4x,8x,16x,32x,64x,128x
1.6Hz (0001)	1x,2x,4x,8x,16x,32x,64x,128x
0.8Hz (0000)	1x,2x,4x,8x,16x,32x,64x,128x

4.2.3.Factory calibration

The IC is factory calibrated for sensitivity (S_0) and Zero-g level ($TyOff$). The trimming values are stored inside the chip's nonvolatile memory. The trimming parameters are loaded to registers while da618G reset (POR or software reset). This allows using the device without further calibration.

4.2.4.Self-test

This feature permits to check the sensor functionality by applying electrostatic forces to the sensor core instead of external accelerations. By actually deflecting the seismic mass, the entire signal path of the sensor can be tested. Activating the self-test results in a static offset of the acceleration data; any external acceleration or gravitational force applied to the sensor during active self-test will be observed in the output as a superposition of both acceleration and self-test signal.

When self-test is enabled by writing '1'('0') to bit (0x11) 'Self_test'. It will change 375 +/-175mg on the signal chain (Three axis data).

4.3. Interrupt controller

Interrupt engines are integrated in the da618G. Each interrupt can be independently enabled and configured. If the condition of an enabled interrupt is fulfilled, the corresponding status bit is set to 1 and the selected interrupt pin is activated. There are two interrupt pins, INT1 and INT2; interrupts can be freely mapped to any of these two pins. The pin state is a logic ‘or’ combination of all mapped interrupts.

4.3.1. General features

An interrupt is cleared depending on the selected interrupt mode, which is common to all interrupts. There are three different interrupt modes: non-latched, latched and temporary. The mode is selected by the ‘latch_int’ bits according to the following table.

Table 15. Interrupt mode selection

latch_int1/2	Interrupt mode
0000	non-latched
0001	temporary latched 250ms
0010	temporary latched 500ms
0011	temporary latched 1s
0100	temporary latched 2s
0101	temporary latched 4s
0110	temporary latched 8s
0111	latched
1000	non-latched
1001	temporary latched 1ms
1010	temporary latched 1ms
1011	temporary latched 2ms
1100	temporary latched 25ms
1101	temporary latched 50ms
1110	temporary latched 100ms
1111	latched

An interrupt is generated if its activation condition is met. It can’t be cleared as long as the activation condition is fulfilled. In the non-latched mode the interrupt status bit and the selected pin (INT1 or INT2) are cleared as soon as the activation condition is no more valid. Exceptions to this behavior are the new data and orientation, which are automatically reset after a fixed time.

In the latched mode an asserted interrupt status and the selected pin are cleared by writing 1 to (0x20) ‘reset_int’ bit. If the activation condition still holds when it is cleared, the interrupt status is asserted again with the next change of the acceleration registers.

In the temporary mode an asserted interrupt and selected pin are cleared after a defined period of time. The behavior of the different interrupt modes is shown in the following figure.

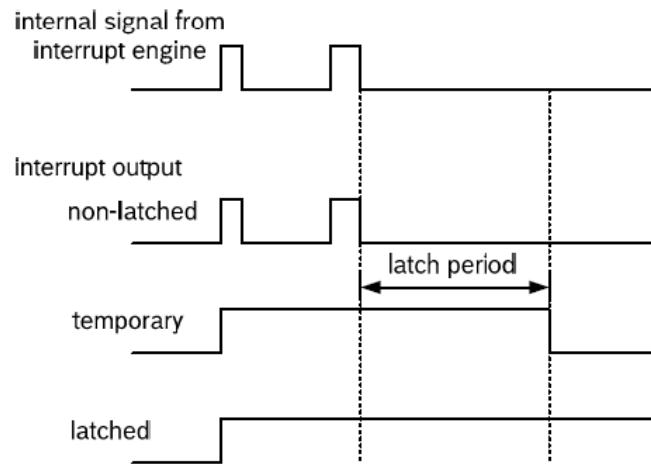

Figure 9 Interrupt mode

4.3.2.Mapping

The mapping of interrupts to the interrupt pins is done by registers 'INT_MAP' (0x19 0x1a and 0x1b), setting *int1_inttype* (e.g. *int1_freefall*) to 1 can map this type of interrupt to INT1 pin and setting *int2_inttyp* to 1 can map this type interrupt to INT2 pin.

4.3.3.Electrical behavior (INT1/INT2 to open-drain or push-pull)

Both interrupt pins can be configured to show desired electrical behavior. The active level for each pin is set by register bit *int1_lv1* (*int2_lv1*), if *int1_lv1* (*int2_lv1*) = 0 (1), then the pin INT1 (INT2) is 1 (0) active.

Also the electric type of the interrupt pin can be selected. By setting *int1_od* (*int2_od*) = 1 (0), the interrupt pin output type can be set to be open-drain (push-pull).

4.3.4.New data interrupt

This interrupt serves for synchronous reading of acceleration data. It is generated after an acceleration data was calculated. The interrupt is cleared automatically before the next acceleration data is ready.

4.3.5.Active/Inactive detection

The active interrupt status is stored in the (0x09) 'active/inactive_int' bit. The (0x0b) bit 'active_first_x/y/z' records which axis triggered the active interrupt first and the sign of this acceleration data that triggered the interrupt is recorded in the (0x0b) bit 'active_sign'.

Active detection uses the slope between successive acceleration signals to detect changes in motion. An interrupt is generated when the slope (absolute value of acceleration difference) exceeds a preset threshold. The threshold is set with the value of register 'active_th' with the LSB corresponding to 16 LSB of acceleration data, that is 3.9mg in 2g-range, 7.8mg in 4g-range, 15.6mg in 8g-range and 31.3mg in 16g-range. And the maximum value is 1g in 2g-range, 2g in 4g-range, 4g in 8g-range and 8g in 16g-range.

The time difference between the successive acceleration signals depends is fixed to 1ms.

Active detection can be enabled (disabled) for each axis separately by writing '1' to bits 'active_en_x/y/z'. The active interrupt is generated if the slope of any of the enabled axes exceeds the threshold for ['active_dur'+1] consecutive times. As soon as the slopes of all enabled axes fall below this threshold for ['active_dur'+1] consecutive times, the interrupt is cleared unless the interrupt signal is latched.

The interrupt status is stored in bit 'active_int'. The bit 'active_first_x/y/z' record which axis triggered the active interrupt first and the sign of this acceleration data that triggered the interrupt is recorded in the bit 'active_sign'.

For inactive, The interrupt status is stored in the same bit (0x09) 'inactive_int' bit, when active_sel is setting '1'.

The status bits ('Active/inactive_int' bit) can be defined according to the following table.

Active_sel (0x17)	Active/Inactive int (0x09)	Description
0	0	No int
0	1	Active int
1	0	No int
1	1	Inactive int

4.3.6. Tap detection

Tap detection has a functional similarity with a common laptop touch-pad or clicking keys of a computer mouse. A tap event is detected if a pre-defined pattern of the acceleration slope is fulfilled at least for one axis. Two different tap events are distinguished: A single tap is a single event within a certain time, followed by a certain quiet time. A double tap consist a first such event followed by a second event within a defined time.

Single tap interrupt is enabled by writing 1 to bit 's_tap_int_en' and double tap interrupt is enabled by writing 1 to bit 'd_tap_int_en'. The status of the single tap interrupt is stored in bit 's_tap_int' and the status of the double tap interrupt is stored in bit 'd_tap_int'.

The slope threshold for detecting a tap event is set by bits "tap_th" with the LSB corresponding to 256LSB of acceleration data that is 62.5mg in 2g-range, 125mg in 4g-range, 250mg in 8g-range, 500mg in 16g-range. And the maximum value equals to the full scale in each range.

The following figure meaning of different timing parameter is visualized.

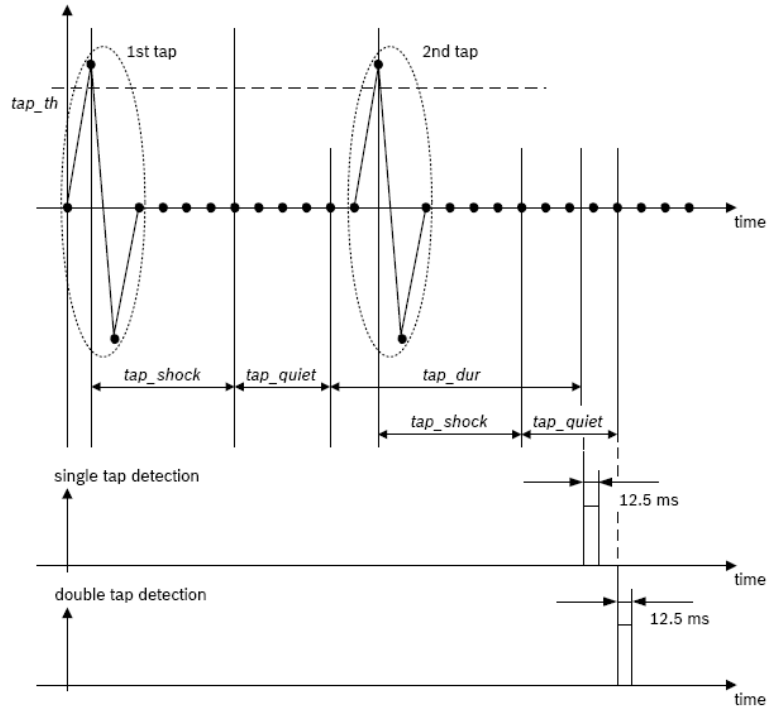

Figure 10 Timing of tap detection

Tap event happens once there's signal exceeds ' tap_th ' and ODR will change to fixed 800Hz at this point. Any slope exceeding ' tap_th ' in ' tap_shock ' after the first event will be ignored. If there's any slope exceeding ' tap_th ' during ' tap_quiet ', tap event will be aborted. And once tap event is aborted, ODR will change back to configured value.

If only ' $s_tap_int_en$ ' is enabled and corresponding slope conditions are fulfilled, a single tap is detected and the single tap interrupt is generated after the combination duration of ' tap_shock ', ' tap_quiet ' and ' tap_dur '. The interrupt is cleared after a delay of 12.5ms in non-latched mode.

If ' $d_tap_int_en$ ' is enabled and a single tap occurs again within the set duration in ' tap_dur ' after the completion of the first tap event, a double tap is detected and the double tap interrupt is generated. The interrupt is cleared after a delay of 12.5ms in non-latched mode.

If both ' $s_tap_int_en$ ' and ' $d_tap_int_en$ ' are enabled, double tap interrupt is generated if double tap conditions are satisfied and single tap interrupt will be generated while meets single tap conditions but not double tap condition.

The sign of the slope of the first tap which triggered the interrupt is stored in bit ' tap_sign ' (0 means positive, 1 means negative). The axis which triggered the interrupt is indicated by bits ' $tap_first_x/y/z$ '.

4.3.7.Orientation recognition

The orientation recognition feature informs on an orientation change of sensor with respect to the gravitation field vector 'g'. The measured acceleration vector components with respect to the gravitation field are defined as shown in the following figure.

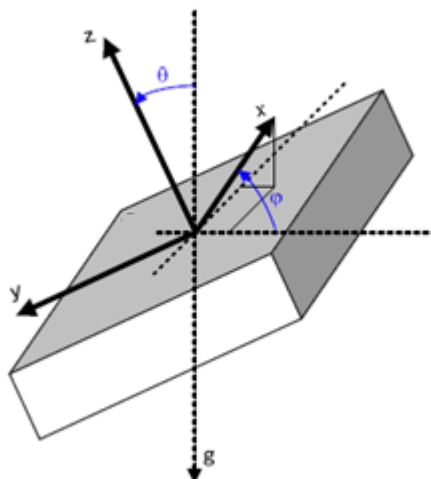

Figure 11 Definition of vector components

Therefore, the magnitudes of the acceleration vectors are calculated as follows:

$$acc_x = 1g \cdot \sin \theta \cdot \cos \varphi$$

$$acc_y = -1g \cdot \sin \theta \cdot \sin \varphi$$

$$acc_z = 1g \cdot \cos \theta$$

Depending on the magnitudes of the acceleration vectors the orientation of the device in the space is determined and stored in the (0x09) 'orient_int' bit. There are three orientation calculation modes with different thresholds for switching between different orientations: symmetrical, high-asymmetrical and low-asymmetrical. The mode is selected by setting the (0x2c) 'orient_mode' bit. For each orientation mode, the 'orient' bits have a different meaning as show in the following tables.

Table 16.meaning of 'orient' bits in symmetric mode

Orient	Name	Angle	Condition
X00	Portrait upright	$315^\circ < \varphi < 45^\circ$	$ acc_y < acc_x - 'hyst' \ \&acc_x \geq 0$
X01	Portrait upside down	$135^\circ < \varphi < 225^\circ$	$ acc_y < acc_x - 'hyst' \ \&acc_x < 0$
X10	Landscape left	$45^\circ < \varphi < 135^\circ$	$ acc_y \geq acc_x + 'hyst' \ \& \ acc_y < 0$
X11	Landscape right	$225^\circ < \varphi < 315^\circ$	$ acc_y \geq acc_x + 'hyst' \ \& \ acc_y \geq 0$

Table 17.meaning of 'orient' bits in high-asymmetric mode

Orient	Name	Angle	Condition
X00	Portrait upright	$297^\circ < \varphi < 63^\circ$	$ acc_y < 2* acc_x - 'hyst' \ \&acc_x \geq 0$
X01	Portrait upside down	$117^\circ < \varphi < 243^\circ$	$ acc_y < 2* acc_x - 'hyst' \ \&acc_x < 0$
X10	Landscape left	$63^\circ < \varphi < 117^\circ$	$ acc_y \geq 2* acc_x + 'hyst' \ \& \ acc_y < 0$

X11	Landscape right	$243^\circ < \varphi < 297^\circ$	$ \text{acc}_y \geq 2 * \text{acc}_x + \text{'hyst' } \& \text{acc}_y \geq 0$
-----	-----------------	-----------------------------------	--

Table 18.meaning of ‘orient’ bits in low-asymmetric mode

Orient	Name	Angle	Condition
X00	Portrait upright	$333^\circ < \varphi < 27^\circ$	$ \text{acc}_y < 0.5 * \text{acc}_x - \text{'hyst' } \& \text{acc}_x \geq 0$
X01	Portrait upside down	$153^\circ < \varphi < 207^\circ$	$ \text{acc}_y < 0.5 * \text{acc}_x - \text{'hyst' } \& \text{acc}_x < 0$
X10	Landscape left	$27^\circ < \varphi < 153^\circ$	$ \text{acc}_y \geq 0.5 * \text{acc}_x + \text{'hyst' } \& \text{acc}_y < 0$
X11	Landscape right	$207^\circ < \varphi < 333^\circ$	$ \text{acc}_y \geq 0.5 * \text{acc}_x + \text{'hyst' } \& \text{acc}_y \geq 0$

In the preceding tables, the parameter ‘hyst’ stands for a hysteresis which can be selected by the (0x2c) ‘orient_hyst’ bit. 1LSB of ‘orient_hyst’ always corresponds to 62.5mg in any g-range. The MSB of ‘orient’ bits contains information about the direction of the z-axis. It is set to 0(1) if $\text{acc}_z \geq 0$ ($\text{acc}_z < 0$). The hysteresis for z axis is fixed to 0.2g.

The orient interrupt is enabled by writing the (0x16) ‘orient_int_en’ bit. The interrupt is generated if the value of ‘orient’ has changed. It is automatically cleared after one stable period of the orient value in non-latched mode. In temporary latched or latched mode, the orient value is kept fixed as long as the interrupt persists. After cleaning the interrupt, the ‘orient’ will updated with the next following value change.

The change of the ‘orient’ value and the generation of the interrupt can be blocked according to conditions selected by setting the value of the (0x2c) ‘orient_block’ bit as described by the following table.

Table 19.blocking conditions for orientation recognition

Orient_block	Conditions
00b	No blocking
01b	Z blocking
10b	Z blocking or acceleration slope in any axis > 0.2g
11b	No blocking

The Z blocking is defined by the following inequality:

$$|\text{acc}_z| > z_blocking$$

The parameter z_blocking of the above given equation stands for the contents of the (0x2d) ‘z_blocking’ bit. Hereby it is possible to define a blocking value between 0g and 0.9375g with an LSB = 0.0625g.

4.3.8.Freefall interrupt

This interrupt is based on the comparison of acceleration data against a low-g threshold. The interrupt is enabled by writing 1 to the (0x17) ‘freefall_int_en’ bit. There are two modes available: single mode and sum mode. In single mode the acceleration of each axis is compared with the threshold. In sum mode, the sum of absolute values of all accelerations $|\text{acc}_x| + |\text{acc}_y| + |\text{acc}_z|$ is compared with the threshold. The mode is selected by the (0x24) ‘freefall_mode’ bit. The free fall threshold is set through the (0x23) ‘freefall_th’ bits with 1 LSB corresponding to an acceleration of 7.81mg. A hysteresis can be selected by setting the (0x24) ‘freefall_hy’ bits with 1 LSB corresponding to 125mg.

The freefall interrupt is generated if the absolute values of the acceleration of all axes or their sum are lower than the threshold for at least the time defined by the (0x22) ‘freefall_dur’ bits. The interrupt is reset if the absolute value of at least one axis or the sum is higher than the threshold plus the hysteresis for at least one data acquisition. The interrupt status is stored in the (0x09) ‘freefall_int’ bit.

5. Digital blocks

5.1. FIFO

The da618G embeds 32-level of 16-bit data FIFO for each of the three output channels, X, Y and Z of the acceleration module that can be used to minimize host processor burden. This buffer has four modes: bypass, FIFO, stream, and trigger. Each mode is selected by the settings of the ‘FIFO_mode’ bits.

5.1.1. Bypass Mode

In bypass mode, FIFO is not operational and, therefore, remains empty.

5.1.2. FIFO Mode

In FIFO mode, acceleration data of the x, y, and z-axes are stored in FIFO. When the number of samples in FIFO equals the level specified in the “watermark_samples” bits, the watermark interrupt is set. FIFO continues accumulating samples until it is full and then stops collecting data. After FIFO stops collecting data, the device continues to operate; therefore, features such as tap detection can be used after FIFO is full. The watermark interrupt continues to occur until the number of samples in FIFO is less than the value stored in the samples bits of the “watermark_samples” bits.

5.1.3. Stream Mode

In stream mode, acceleration data of the x, y, and z-axes are stored in FIFO. When the number of samples in FIFO equals the level specified in the “watermark_samples” bits, the watermark interrupt is set. FIFO continues accumulating samples and holds the latest 32 samples from measurements of the x, y, and z-axes, discarding older data as new data arrives. The watermark interrupt continues occurring until the number of samples in FIFO is less than the value stored in the samples bits of the “watermark_samples” bits.

5.1.4. Trigger Mode

In trigger mode, FIFO accumulates samples, holding the latest 32 samples from measurements of the x, y, and z-axes. After an enable interrupt event occurs, FIFO keeps the last n samples (where n is the value specified by the ‘watermark_samples’ bits) and then operates in FIFO mode, collecting new samples only when FIFO is not full. Additional trigger events cannot be recognized until the trigger mode is reset. To reset the trigger mode, set the device to bypass mode and then set the device back to trigger mode. Note that the FIFO data should be read first because placing the device into bypass mode clears FIFO.

5.1.5. Retrieving Data from FIFO

The FIFO data is read through the ‘acc_x’, ‘acc_y’, and ‘acc_z’ registers. When the FIFO is in FIFO, stream, or trigger mode, reads to the ‘acc_x’, ‘acc_y’, and ‘acc_z’ registers read data stored in the FIFO. Each time data is read from the FIFO, the oldest x, y, and z-axes data

are placed into the 'acc_x', 'acc_y', and 'acc_z' registers.

If a single-byte read operation is performed, the remaining bytes of data for the current FIFO sample are lost. Therefore, all axes of interest should be read in a burst (or multiple-byte) read operation.

It is recommended to read all FIFO data in a burst read of 'fifo_entries' *6 bytes. For example, when 'fifo_entries' = 32(max), the bytes are 192(32*6). In order to minimize communication between the master and slave, the reading address may be automatically incremented/decremented by the device in LSB-first mode/ MSB-first mode. In LSB-first mode, the device rolls back to 0x02 when register 0x07 is reached. In MSB-first mode, the device rolls back to 0x07 when register 0x02 is reached.

5.2. Embedded functions

The da618G embeds internal logic able to implement the following functions:

- Step counter
- Step detector
- Significant motion
- Tilt
- Flat
- Tilt on wrist

5.2.1. Step counter

When step counter is enable by set "step_en", the step counter counts the number of the steps, and recognize out the current status of walk or run.

5.2.2. Step detector

When step counter is enable and step detector interrupt is enable by set "step_int_en", the step detector function generates an interrupt when a step is recognized.

5.2.3. Significant motion

When step counter is enable and significant motion interrupt is enable by set "SM_int_en", the significant motion generates an interrupt when a 'significant motion', that could be due to a change in user location, is detected.

If the change in user is valid which is judged by the steps difference between its initialization steps and current steps that is higher or equal than the steps threshold of "SM_THRESHOLD" (34H) register.

5.2.4. Tilt

When tilt is enable by set "tilt_int_en", the tilt function generates an interrupt when an activity change occurs that is the device is tilted by an angle greater than "tilt_threshold" from the start position. The start position is defined as the position of the device when tilt detection is enabled or position of the device when the last tilt interrupt was generated.

5.2.5.Flat detection

The flat detection feature gives information about whether the device is in a flat position or not.

The flat interrupt is enabled(disabled) by writing '1'('0') to bit (0x17) 'Flat_int_en'. The flat value is stored in the (0x0A) 'Flat_int'. The flat interrupt is generated if the values of x axis and y axis are lower than the threshold setting by the (0x25) 'Flat_th' bits for at least the time defined by the (0x24) 'Flat_dur' bits.

Flat threshold can be selected by setting the (0x25) 'Flat_th' bits with 1 LSB corresponding to 15.6mg. Flat duration can be selected by setting the (0x24) 'Flat_dur' bits with duration time = $(4 * \text{Flat_dur} + 1) * 1 / \text{ODR}$. A hysteresis can be selected by setting the (0x25) 'Flat_hy' bits with 1 LSB corresponding to 3.9mg.

5.2.6.Tilt on wrist

How to perform the "Tilt on Wrist" gesture ideally:

1. Wrap the device on your wrist.
2. Lift the hand wearing the device up to a horizontal or inner position. (see the image below for the valid position)
3. Wait for 0.5 second.

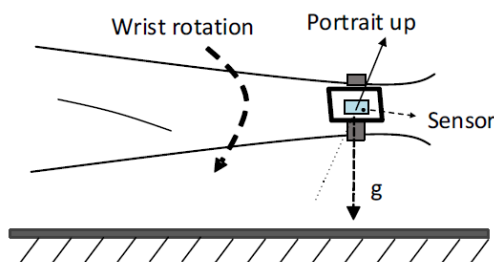
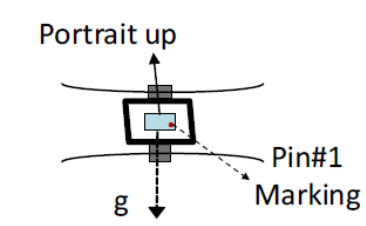
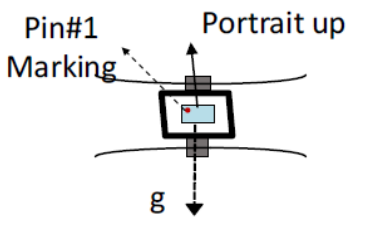
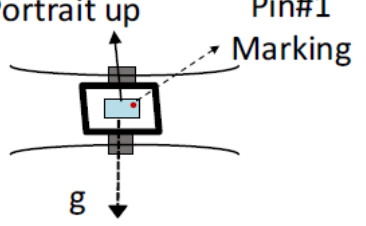
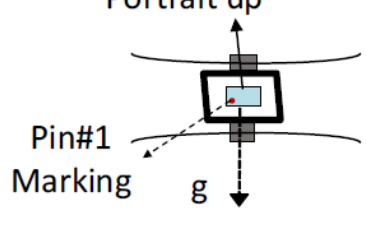
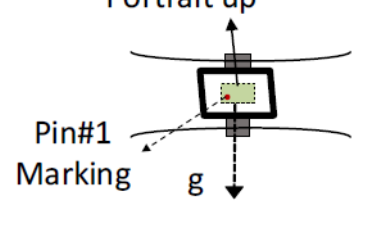
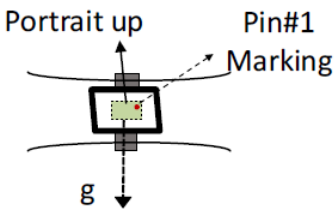
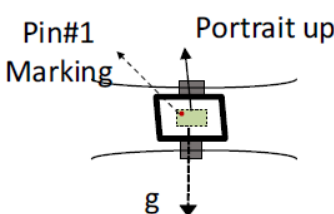
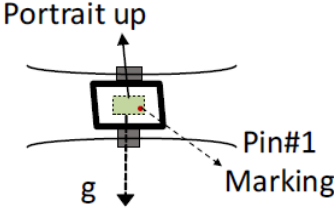

Figure 12 Valid position for Tilt on Wrist

The Tilt on Wrist interrupt is detected with one accelerometer axis. Therefore, you should make sure that the active axis is mapped to the portrait up direction of the device by using the axis remapping functionality of da618G.

The table below shows the required remapping configurations for the Tilt on Wrist function based on the sensor's different orientations inside the device.

No.	Sensor direction	Mount layer	Register configuration	Remarks
1	 <p>Portrait up Pin#1 Marking g</p>	Top layer	$X_Y_swap = 0$ $X_polarity = 1$ $Y_polarity = 1$ $Z_polarity = 1$	$X = +x$ axis $Y = +y$ axis $Z = +z$ axis Same as the original mapping
2	 <p>Pin#1 Marking Portrait up g</p>	Top layer	$X_Y_swap = 0$ $X_polarity = 0$ $Y_polarity = 0$ $Z_polarity = 1$	$X = -x$ axis $Y = -y$ axis $Z = +z$ axis x,y inverted
3	 <p>Portrait up Pin#1 Marking g</p>	Top layer	$X_Y_swap = 1$ $X_polarity = 0$ $Y_polarity = 1$ $Z_polarity = 1$	$X = -y$ axis $Y = +x$ axis $Z = +z$ axis x,y swapped,and x inverted
4	 <p>Portrait up Pin#1 Marking g</p>	Top layer	$X_Y_swap = 1$ $X_polarity = 1$ $Y_polarity = 0$ $Z_polarity = 1$	$X = y$ axis $Y = -x$ axis $Z = +z$ axis x,y swapped,and y inverted
5	 <p>Portrait up Pin#1 Marking g</p>	Bottom layer	$X_Y_swap = 0$ $X_polarity = 0$ $Y_polarity = 1$ $Z_polarity = 0$	$X = -x$ axis $Y = y$ axis $Z = -z$ axis x,z inverted

<p>6</p>		<p>Bottom layer</p>	<p>$X_Y_swap = 0$ $X_polarity = 1$ $Y_polarity = 0$ $Z_polarity = 0$</p>	<p>$X = x$ axis $Y = -y$ axis $Z = -z$ axis y,z inverted</p>
<p>7</p>		<p>Bottom layer</p>	<p>$X_Y_swap = 1$ $X_polarity = 1$ $Y_polarity = 1$ $Z_polarity = 0$</p>	<p>$X = y$ axis $Y = x$ axis $Z = -z$ axis x,y swapped, and z inverted</p>
<p>8</p>		<p>Bottom layer</p>	<p>$X_Y_swap = 1$ $X_polarity = 0$ $Y_polarity = 0$ $Z_polarity = 0$</p>	<p>$X = -y$ axis $Y = -x$ axis $Z = -z$ axis x,y swapped, and x,y,z inverted</p>

6. Application hints

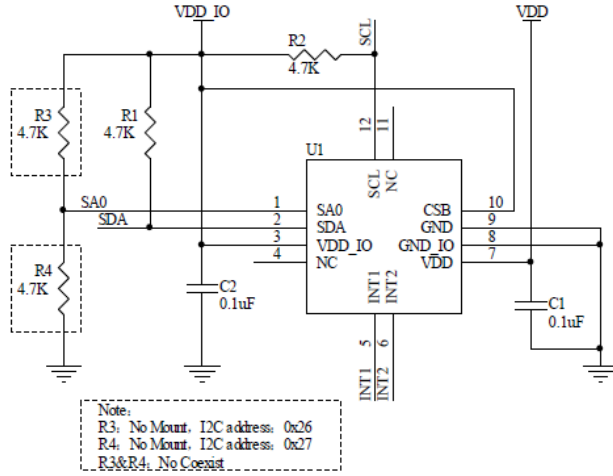

Figure 13 da618G I2C electrical connect

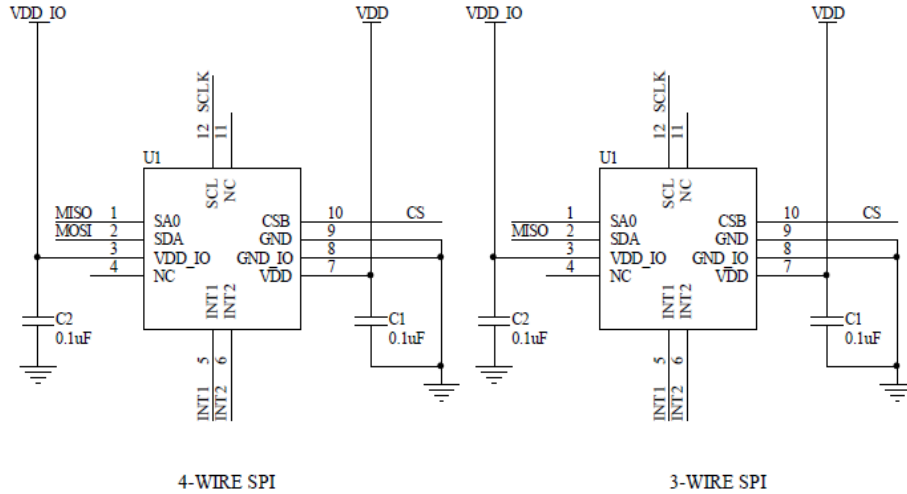

Figure 14 da618G SPI electrical connect

The device core is supplied through VDD line while the I/O pads are supplied through VDD_IO line. Power supply decoupling capacitors (100 nF ceramic) should be placed as near as possible to the pin 7 and pin 3 of the device (common design practice).

The functionality of the device and the measured acceleration data is selectable and accessible through the I2C or SPI interfaces. When using the I2C, CSB must be tied high. The functions, the threshold and the timing of the two interrupt pins (INT1 and INT2) can be completely programmed by the user through the I2C/SPI interface.

7. Register mapping

The table given below provides a listing of the 8 bit registers embedded in the device and the related addresses:

Table 20. Register address map

Name	Type	Register address	Default	Soft Reset
SPI_CONFIG	RW	0x00	81H	NO
CHIP_ID	R	0x01	13H	NO
ACC_X_LSB	R	0x02	00H	YES
ACC_X_MSB	R	0x03	00H	YES
ACC_Y_LSB	R	0x04	00H	YES
ACC_Y_MSB	R	0x05	00H	YES
ACC_Z_LSB	R	0x06	00H	YES
ACC_Z_MSB	R	0x07	00H	YES
FIFO_STATUS	R	0x08	00H	YES
MOTION_FLAG1	R	0x09	00H	YES
MOTION_FLAG2	R	0x0A	00H	YES
TAP_ACTIVE_STATUS	R	0x0B	00H	YES
ORIENT_STATUS	R	0x0C	00H	YES
STEPS_MSB	R	0x0D	00H	YES
STEPS_LSB	R	0x0E	00H	YES
RESOLUTION_RANGE	RW	0x0F	60H	YES
MODE_ODR	RW	0x10	17H	YES
MODE_AXIS	RW	0x11	80H	YES
SWAP_POLARITY	RW	0x12	0EH	YES
FIFO_CTRL	RW	0x14	00H	YES
INT_SET0	RW	0x15	00H	YES
INT_SET1	RW	0x16	00H	YES
INT_SET2	RW	0x17	00H	YES
INT_MAP1	RW	0x19	00H	YES
INT_MAP2	RW	0x1A	00H	YES
INT_MAP3	RW	0x1B	00H	YES
INT_MAP4	RW	0x1C	00H	YES
INT_CONFIG	RW	0x20	00H	YES
INT_LATCH	RW	0x21	00H	YES
FREEFALL_DUR	RW	0x22	09H	YES
FREEFALL_THS	RW	0x23	30H	YES
FREEFALL_HYST	RW	0x24	09H	YES
FLAT_TH	RW	0x25	81H	YES
TAP_QUIET	RW	0x29	08H	YES
TAP_DUR	RW	0x2A	24H	YES
TAP_THS	RW	0x2B	0AH	YES
ORIENT_HYST	RW	0x2C	18H	YES

Z_BLOCK	RW	0x2D	88H	YES
RESET_STEP	RW	0x2E	00H	YES
STEP_FILTER	RW	0x33	25H	YES
SM_THRESHOLD	RW	0x34	32H	YES
ACTIVE_DUR	RW	0x38	00H	YES
ACTIVE_X_THS	RW	0x39	14H	YES
ACTIVE_Y_THS	RW	0x3A	14H	YES
ACTIVE_Z_THS	RW	0x3B	14H	YES

8. Registers description

8.1.SPI_CONFIG (00H)

Table 21.SPI_CONFIG register

Default data: 0x81 Type: RW

SDO Active	LSB First	Soft Reset	Unused	Unused	Soft Reset	LSB First	SDO Active
------------	-----------	------------	--------	--------	------------	-----------	------------

Table 22.SPI_CONFIG description

SDO Active	0: 3-wire SPI 1: 4-wire SPI
LSB First	0: MSB First 1: LSB First
Soft Reset	1: soft reset

8.2.CHIP_ID (01H)

Table 23.CHIP_ID register

Default data: 0x13 Type: R

0	0	0	1	0	0	1	1
---	---	---	---	---	---	---	---

8.3.ACC_X_LSB (02H), ACC_X_MSB (03H)

X-axis acceleration data, the value is expressed in two complement byte and are left justified.

Table 24.ACC_X_LSB register

Default data: 0x00 Type: R

D[7]	D[6]	D[5]	D[4]	D[3]	D[2]	D[1]	D[0]
------	------	------	------	------	------	------	------

Table 25.ACC_X_MSB register

Default data: 0x00 Type: R

D[15]	D[14]	D[13]	D[12]	D[11]	D[10]	D[9]	D[8]
-------	-------	-------	-------	-------	-------	------	------

8.4. ACC_Y_LSB (04H), ACC_Y_MSB (05H)

Y-axis acceleration data, the value is expressed in two complement byte and are left justified.

Table 26.ACC_Y_LSB register

Default data: 0x00 Type: R

D[7]	D[6]	D[5]	D[4]	D[3]	D[2]	D[1]	D[0]
------	------	------	------	------	------	------	------

Table 27.ACC_Y_MSB register

Default data: 0x00 Type: R

D[15]	D[14]	D[13]	D[12]	D[11]	D[10]	D[9]	D[8]
-------	-------	-------	-------	-------	-------	------	------

8.5. ACC_Z_LSB (06H), ACC_Z_MSB (07H)

Z-axis acceleration data, the value is expressed in two complement byte and are left justified.

Table 28.ACC_Z_LSB register

Default data: 0x00 Type: R

D[7]	D[6]	D[5]	D[4]	D[3]	D[2]	D[1]	D[0]
------	------	------	------	------	------	------	------

Table 29.ACC_Z_MSB register

Default data: 0x00 Type: R

D[15]	D[14]	D[13]	D[12]	D[11]	D[10]	D[9]	D[8]
-------	-------	-------	-------	-------	-------	------	------

8.6. FIFO_STATUS (08H)

Table 30.FIFO_STATUS register

Default data: 0x00 Type: R

Watermark_int	FIFO_full_int	FIFO_entries[5]	FIFO_entries[4]	FIFO_entries[3]	FIFO_entries[2]	FIFO_entries[1]	FIFO_entries[0]
---------------	---------------	-----------------	-----------------	-----------------	-----------------	-----------------	-----------------

Table 31. FIFO_STATUS register description

Watermark_int	1: the FIFO entries exceed the watermark level
FIFO_full_int	1: the FIFO is full
FIFO_entries[5:0]	FIFO_entries[5:0] reports how many data stored in the FIFO

8.7.MOTION_FLAG1 (09H)

Table 32.MOTION_FLAG1 register

Default data: 0x00 Type: R

Step_int	Orient_int	S_tap_int	D_tap_int	SM_int	Active/Inactive_int	Tilt_int	Freefall_int
----------	------------	-----------	-----------	--------	---------------------	----------	--------------

Table 33.MOTION_FLAG1 register description

Step_int	0: no step 1: one step detected
Orient_int	0: no orient interrupt 1: orient interrupt has occurred
S_tap_int	0: no single tap interrupt 1: single tap interrupt has occurred
D_tap_int	0: no double tap interrupt 1: double tap interrupt has occurred
SM_int	0: no significant motion 1: significant motion has been detected
Active/Inactive_int	When active_sel=0 0: no active interrupt 1: active interrupt has occurred When active_sel=1 0: no inactive interrupt 1: inactive interrupt has occurred
Tilt_int	0: no tilt interrupt 1: tilt interrupt has occurred
Freefall_int	0: no freefall interrupt 1: freefall interrupt has occurred

8.8.MOTION_FLAG2 (0AH)

Table 34.MOTION_FLAG2 register

Default data: 0x00 Type: R

Unused	Unused	Unused	Unused	Unused	tilt_on_wrist_int	flat_int	new_data_int
--------	--------	--------	--------	--------	-------------------	----------	--------------

Table 35.MOTION_FLAG2 register description

tilt_on_wrist_int	0: no tilt on wrist interrupt 1: tilt on wrist interrupt has occurred
flat_int	0: no flat interrupt 1: flat interrupt has occurred
new_data_int	0: new data not ready 1: new data has ready

8.9.TAP_ACTIVE_STATUS (0BH)

Table 36.TAP_ACTIVE_STATUS register

Default data: 0x00 Type: R

Tap_sign	Tap_first_x	Tap_first_y	Tap_first_z	Active_sign	Active_first_x	Active_first_y	Active_first_z
----------	-------------	-------------	-------------	-------------	----------------	----------------	----------------

Table 37.TAP_ACTIVE_STATUS register description

Tap_sign	sign of the first tap that triggered interrupt 0: positive 1: negative
Tap_first_x	0: X is not the triggering axis of the tap interrupt 1: indicate X is the triggering axis of the tap interrupt
Tap_first_y	0: Y is not the triggering axis of the tap interrupt 1: indicate Y is the triggering axis of the tap interrupt
Tap_first_z	0: Z is not the triggering axis of the tap interrupt 1: indicate Z is the triggering axis of the tap interrupt
Active_sign	active_sign: Sign of the first active interrupt 0: positive 1: negative
Active_first_x	0: X is not the triggering axis of the active interrupt 1: indicate X is the triggering axis of the active interrupt
Active_first_y	0: Y is not the triggering axis of the active interrupt 1: indicate Y is the triggering axis of the active interrupt
Active_first_z	0: Z is not the triggering axis of the active interrupt 1: indicate Z is the triggering axis of the active interrupt

8.10. ORIENT_STATUS (0CH)

Table 38. ORIENT_STATUS register

Default data: 0x00 Type: R

Unused	Orient[2]	Orient[1]	Orient[0]	Unused	Unused	Step_stauts[1]	Step_stauts[0]
--------	-----------	-----------	-----------	--------	--------	----------------	----------------

Table 39. ORIENT_STATUS register description

Orient[2]	orientation value of 'z' axis 0: upward looking 1: downward looking
Orient[1:0]	orientation value of 'x', 'y' axes 00: portrait upright 01: portrait upside down 10: landscape left 11: landscape right
Step_status[1:0]	00/11: idle 01: walk 10: run

8.11. STEPS_MSB (0DH), STEPS_LSB (0EH)

Table 40. STEPS_MSB register

Default data: 0x00 Type: R

Steps[15]	Steps [14]	Steps [13]	Steps [12]	Steps [11]	Steps [10]	Steps [9]	Steps [8]
-----------	------------	------------	------------	------------	------------	-----------	-----------

Table 41. STEPS_MSB register description

Steps[15:8]	step counter output(MSbyte)
-------------	-----------------------------

Table 42. STEPS_LSB register

Default data: 0x00 Type: R

Steps [7]	Steps [6]	Steps [5]	Steps [4]	Steps [3]	Steps [2]	Steps [1]	Steps [0]
-----------	-----------	-----------	-----------	-----------	-----------	-----------	-----------

Table 43. STEPS_LSB register description

Steps[7:0]	step counter output(LSbyte)
------------	-----------------------------

8.12. RESOLUTION_RANGE (0FH)

Table 44.RESOLUTION_RANGE register

Default data: 0x60 Type: RW

HP_en	Wdt_en	Wdt_time	Unused	Resolution[1]	Resolution[0]	FS[1]	FS[0]
-------	--------	----------	--------	---------------	---------------	-------	-------

Table 45.RESOLUTION_RANGE register description

HP_en	0: disable high pass filter 1: enable high pass filter
Wdt_en	0: disable watch dog 1: enable watch dog
Wdt_time	0: 2ms 1: 50ms
Resolution[1:0]	00: 16bit 01: 12bit 10: 10bit 11: 8bit
FS[1:0]	full scale 00: +/-2g 01: +/-4g 10: +/-8g 11: +/-16g

8.13. MODE_ODR (10H)

Table 46.MODE_ODR register

Default data: 0x17 Type: RW

Perf_mode	Perf_level[2]	Perf_level[1]	Perf_level[0]	ODR[3]	ODR[2]	ODR[1]	ODR[0]
-----------	---------------	---------------	---------------	--------	--------	--------	--------

Table 47.MODE_ODR register description

Perf_mode	0: low-power mode 1: performance mode
Perf_level[2:0]	when perf_mode=1 0: level0 1: level1 2: level2 3: level3 4~7: reserve when perf_mode=0 0: osr1x 1: osr2x 2: osr4x 3: osr8x 4: osr16x 5: osr32x 6: osr64x 7: osr128x
ODR[3:0]	0000: 0.8Hz 0001: 1.6Hz 0010: 3.125Hz 0011: 6.25Hz 0100: 12.5Hz 0101: 25Hz 0110: 50Hz 0111: 100Hz 1000: 200Hz 1001: 400Hz 1010: 800Hz 1011: 1600Hz 1100-1111: Reserve

8.14. MODE_AXIS (11H)

Table 48.MODE_AXIS register

Default data: 0x80 Type: RW

PWR_OFF	Unused	Unused	Self_test	X-axis_disable	Y-axis_disable	Z-axis_disable	Autosleep_en
---------	--------	--------	-----------	----------------	----------------	----------------	--------------

Table 49.MODE_AXIS register description

PWR_OFF	0: normal mode 1: suspend mode
Self_test	0: disable self test 1: enable self test
X-axis_disable	0: enable X axis 1: disable X axis
Y-axis_disable	0: enable Y axis 1: disable Y axis
Z-axis_disable	0: enable Z axis 1: disable Z axis
Autosleep_en	0: working the current ODR state all the way 1: working at 25hz in inactive state, automatic switched to normal mode during active state

8.15. SWAP_POLARITY (12H)

Table 50.SWAP_POLARITY register

Default data: 0x0E Type: RW

Swap & Polarity register is OTP register too, OTP address: 0x13

Unused	Unused	Unused	Unused	X_polarity	Y_polarity	Z_polarity	X_Y_swap
--------	--------	--------	--------	------------	------------	------------	----------

Table 51.SWAP_POLARITY register description

X_polarity	0: remain the polarity of X-axis 1: reverse the polarity of X-axis
Y_polarity	0: remain the polarity of Y-axis 1: reverse the polarity of Y-axis
Z_polarity	0: remain the polarity of Z-axis 1: reverse the polarity of Z-axis
X_Y_swap	0: don't swap the output data for X/Y axis 1: swap the output data for X/Y axis

8.16. FIFO_CTRL (14H)

Table 52.FIFO_CTRL register

Default data: 0x00 Type: RW

FIFO_mode[1]	FIFO_mode[0]	FIFO_clr	Watermark_ samples[4]	Watermark_ samples[3]	Watermark_ samples[2]	Watermark_ samples[1]	Watermark_ samples[0]
--------------	--------------	----------	--------------------------	--------------------------	--------------------------	--------------------------	--------------------------

Table 53.FIFO_CTRL register description

FIFO_mode[1:0]	00: bypass mode 01: FIFO mode 10: stream mode 11: trigger mode
FIFO_clr	write 1 to clear FIFO data
Watermark_samples[4:0]	indicate how many data entries needed to trig a watermark interrupt

8.17. INT_SET0 (15H)

Table 54.INT_SET0 register

Default data: 0x00 Type: RW

Unused	Unused	Unused	Tilt_int_en	Watermark_int_en	FIFO_full_int_en	SM_int_en	Step_int_en
--------	--------	--------	-------------	------------------	------------------	-----------	-------------

Table 55.INT_SET0 register description

Tilt_int_en	0: disable 1: enable tilt interrupt
Watermark_int_en	0: disable 1: enable watermark interrupt
FIFO_full_int_en	0: disable 1: enable FIFO_full interrupt
SM_int_en	0: disable 1: enable SM(significant motion) interrupt
Step_int_en	0: disable 1: enable step counter interrupt

8.18. INT_SET1 (16H)

Table 56.INT_SET1 register

Default data: 0x00 Type: RW

INT_source[1]	INT_source[0]	S_tap_int_en	D_tap_int_en	Orient_int_en	Active_int_en_z	Active_int_en_y	Active_int_en_x
---------------	---------------	--------------	--------------	---------------	-----------------	-----------------	-----------------

Table 57.INT_SET1 register description

INT_source[1:0]	00: oversampling data (ODR_period =ODR*OSR) 01: unfiltered data (ODR_period =ODR) 10/11: filtered data (ODR_period =ODR IIR)
S_tap_int_en	0: disable the single tap interrupt 1: enable the single tap interrupt
D_tap_int_en	0: disable the double tap interrupt 1: enable the double tap interrupt
Orient_int_en	0: disable the orient interrupt 1: enable the orient interrupt
Active_int_en_z	0: disable the active interrupt for the z axis 1: enable the active interrupt for the z axis
Active_int_en_y	0: disable the active interrupt for the y axis 1: enable the active interrupt for the y axis
Active_int_en_x	0: disable the active interrupt for the x axis 1: enable the active interrupt for the x axis

8.19. INT_SET2 (17H)

Table 58.INT_SET2 register

Default data: 0x00 Type: RW

Temporary_dis	Temp_dis_time[1]	Temp_dis_time[0]	New_data_int_en	Freefall_int_en	Flat_int_en	Tilt_on_wrist_int_en	Active_sel
---------------	------------------	------------------	-----------------	-----------------	-------------	----------------------	------------

Table 59.INT_SET2 register description

Temporary_dis	temporary disable all interrupts for a short time(configured by temp_dis_time)
Temp_dis_time[1:0]	00: 100ms 01: 1s 10: 2s 11: 4s
New_data_int_en	0: disable the new data interrupt 1: enable the new data interrupt
Freefall_int_en	0: disable the freefall interrupt 1: enable the freefall interrupt
Flat_int_en	0: disable the flat interrupt 1: enable the flat interrupt
Tilt_on_wrist_int_en	0: disable the tilt on wrist interrupt 1: enable the tilt on wrist interrupt
Active_sel	0: enable active int 1: enable inactive int

8.20. INT_MAP1 (19H)

Table 60.INT_MAP1 register

Default data: 0x00 Type: RW

Int1_SM	Int1_orient	Int1_s_tap	Int1_d_tap	Int1_tilt	Int1_active/inactive	Int1_step	Int1_freefall
---------	-------------	------------	------------	-----------	----------------------	-----------	---------------

Table 61.INT_MAP1 register description

Int1_SM	0: doesn't mapping SM interrupt to INT1 1: mapping SM interrupt to INT1
Int1_orient	0: doesn't mapping orient interrupt to INT1 1: mapping orient interrupt to INT1
Int1_s_tap	0: doesn't mapping single tap interrupt to INT1 1: mapping single tap interrupt to INT1
Int1_d_tap	0: doesn't mapping double tap interrupt to INT1 1: mapping double tap interrupt to INT1
Int1_tilt	0: doesn't mapping tilt interrupt to INT1 1: mapping tilt interrupt to INT1
Int1_active/inactive	0: doesn't mapping active/inactive interrupt to INT1, based on active_sel 1: mapping active/inactive interrupt to INT1, based on active_sel
Int1_step	0: doesn't mapping step counter interrupt to INT1 1: mapping step counter interrupt to INT1
Int1_freefall	0: doesn't mapping freefall interrupt to INT1 1: mapping freefall interrupt to INT1

8.21. INT_MAP2 (1AH)

Table 62.INT_MAP2 register

Default data: 0x00 Type: RW

Unused	Unused	Unused	Int1_tilt_on_wrist	Int1_flat	Int1_FIFO_full	Int1_watermark	Int1_new_data
--------	--------	--------	--------------------	-----------	----------------	----------------	---------------

Table 63.INT_MAP2 register description

Int1_tilt_on_wrist	0: doesn't mapping tilt on wrist interrupt to INT1 1: mapping tilt on wrist interrupt to INT1
Int1_flat	0: doesn't mapping flat interrupt to INT1 1: mapping flat interrupt to INT1
Int1_FIFO_full	0: doesn't mapping FIFO full interrupt to INT1 1: mapping FIFO full interrupt to INT1
Int1_watermark	0: doesn't mapping watermark interrupt to INT1 1: mapping watermark interrupt to INT1
Int1_new_data	0: doesn't mapping new data interrupt to INT1 1: mapping new data interrupt to INT1

8.22. INT_MAP3 (1BH)

Table 64.INT_MAP3 register

Default data: 0x00 Type: RW

Int2_SM	Int2_orient	Int2_s_tap	Int2_d_tap	Int2_tilt	Int2_active/inactive	Int2_step	Int2_freefall
---------	-------------	------------	------------	-----------	----------------------	-----------	---------------

Table 65.INT_MAP3 register description

Int2_SM	0: doesn't mapping SM interrupt to INT2 1: mapping SM interrupt to INT2
Int2_orient	0: doesn't mapping orient interrupt to INT2 1: mapping orient interrupt to INT2
Int2_s_tap	0: doesn't mapping single tap interrupt to INT2 1: mapping single tap interrupt to INT2
Int2_d_tap	0: doesn't mapping double tap interrupt to INT2 1: mapping double tap interrupt to INT2
Int2_tilt	0: doesn't mapping tilt interrupt to INT2 1: mapping tilt interrupt to INT2
Int2_active/inactive	0: doesn't mapping active/inactive interrupt to INT2, based on active_sel 1: mapping active/inactive interrupt to INT2, based on active_sel
Int2_step	0: doesn't mapping step counter interrupt to INT2 1: mapping step counter interrupt to INT2
Int2_freefall	0: doesn't mapping freefall interrupt to INT2 1: mapping freefall interrupt to INT2

8.23. INT_MAP4(1CH)

Table 66.INT_MAP4 register

Default data: 0x00 Type: RW

Unused	Unused	Unused	Int2_tilt_on_wrist	Int2_flat	Int2_FIFO_full	Int2_watermark	Int2_new_data
--------	--------	--------	--------------------	-----------	----------------	----------------	---------------

Table 67.INT_MAP3 register description

Int2_tilt_on_wrist	0: doesn't mapping tilt on wrist interrupt to INT2 1: mapping tilt on wrist interrupt to INT2
Int2_flat	0: doesn't mapping flat interrupt to INT2 1: mapping flat interrupt to INT2
Int2_FIFO_full	0: doesn't mapping FIFO full interrupt to INT2 1: mapping FIFO full interrupt to INT2
Int2_watermark	0: doesn't mapping watermark interrupt to INT2 1: mapping watermark interrupt to INT2
Int2_new_data	0: doesn't mapping new data interrupt to INT2 1: mapping new data interrupt to INT2

8.24. INT_CONFIG (20H)

Table 68.INT_CONFIG register

Default data: 0x00 Type: RW

Reset_int	Unused	Unused	Unused	Int2_od	Int2_lvl	Int1_od	Int1_lvl
-----------	--------	--------	--------	---------	----------	---------	----------

Table 69.INT_CONFIG register description

Reset_int	write '1' to reset all latched int
Int2_od	0: select push-pull output for INT2 1: select OD output for INT2
Int2_lvl	0: select active level high for pin INT2 1: select active level low for pin INT2
Int1_od	0: select push-pull output for INT1 1: select OD output for INT1
Int1_lvl	0: select active level high for pin INT1 1: select active level low for pin INT1

8.25. INT_LATCH (21H)

Table 70.INT_LATCH register

Default data: 0x00 Type: RW

Latch_int2[3]	Latch_int2[2]	Latch_int2[1]	Latch_int2[0]	Latch_int1[3]	Latch_int1[2]	Latch_int1[1]	Latch_int1[0]
---------------	---------------	---------------	---------------	---------------	---------------	---------------	---------------

Table 71.INT_LATCH register description

Latch_int2[3:0]	0000: non-latched 0001: temporary latched 250ms 0010: temporary latched 500ms 0011: temporary latched 1s 0100: temporary latched 2s 0101: temporary latched 4s 0110: temporary latched 8s 0111: latched 1000: non-latched 1001: temporary latched 1ms 1010: temporary latched 1ms 1011: temporary latched 2ms 1100: temporary latched 25ms 1101: temporary latched 50ms 1110: temporary latched 100ms 1111: latched
Latch_int1[3:0]	0000: non-latched 0001: temporary latched 250ms 0010: temporary latched 500ms 0011: temporary latched 1s 0100: temporary latched 2s 0101: temporary latched 4s 0110: temporary latched 8s 0111: latched 1000: non-latched 1001: temporary latched 1ms 1010: temporary latched 1ms 1011: temporary latched 2ms 1100: temporary latched 25ms 1101: temporary latched 50ms 1110: temporary latched 100ms 1111: latched

8.26. FREEFALL_DUR (22H)

Table 72.FREEFALL_DUR register

Default data: 0x09 Type: RW

Freefall_dur[7]	Freefall_dur[6]	Freefall_dur[5]	Freefall_dur[4]	Freefall_dur[3]	Freefall_dur[2]	Freefall_dur[1]	Freefall_dur[0]
-----------------	-----------------	-----------------	-----------------	-----------------	-----------------	-----------------	-----------------

Table 73.FREEFALL_DUR register description

Freefall_dur[7:0]	delay time for freefall $delay_time = (freefall_dur + 1) * 2ms$ range from 2ms to 512ms default: 20ms
-------------------	--

8.27. FREEFALL_THS (23H)

Table 74.FREEFALL_THS register

Default data: 0x30 Type: RW

Freefall_th[7]	Freefall_th[6]	Freefall_th[5]	Freefall_th[4]	Freefall_th[3]	Freefall_th[2]	Freefall_th[1]	Freefall_th[0]
----------------	----------------	----------------	----------------	----------------	----------------	----------------	----------------

Table 75.FREEFALL_THS register description

Freefall_th[7:0]	freefall threshold = $freefall_th * 7.81mg$ LSB = 7.81mg default is 375mg
------------------	--

8.28. FREEFALL_HYST (24H)

Table 76.FREEFALL_HYST register

Default data: 0x09 Type: RW

Unused	Unused	Flat_dur[2]	Flat_dur[1]	Flat_dur[0]	Freefall_mode	Freefall_hy[1]	fFreefall_hy[0]
--------	--------	-------------	-------------	-------------	---------------	----------------	-----------------

Table 77.FREEFALL_HYST register description

Flat_dur[2:0]	Flat dur time = $(4*flat_dur+1)* 1/ODR$
Freefall_mode	0: single mode 1: sum mode
Freefall_hy[1:0]	set the hysteresis for freefall detection free fall hysteresis time = $freefall_hy* 125mg$ LSB = 125mg

8.29. FLAT_TH(25H)

Table 78.FLAT_TH register

Default data: 0x81 Type: RW

Flat_th[3]	Flat_th[2]	Flat_th[1]	Flat_th[0]	Flat_hy[3]	Flat_hy[2]	Flat_hy[1]	Flat_hy[0]
------------	------------	------------	------------	------------	------------	------------	------------

Table 79.FLAT_TH register description

Flat_th[3:0]	set the threshold for flat detection When X/Y(mg) < flat_th, device is in flat status LSB = 15.6mg
Flat_hy[3:0]	set the hysteresis for flat detection LSB=3.9mg

8.30. TAP_QUIET(29H)

Table 80.TAP_QUIET register

Default data: 0x08 Type: RW

Tap_quiet[7]	Tap_quiet[6]	Tap_quiet[5]	Tap_quiet[4]	Tap_quiet[3]	Tap_quiet[2]	Tap_quiet[1]	Tap_quiet[0]
]]]]]]]]

Table 81.TAP_QUIET register description

Tap_quiet[7:0]	range: 0-1020ms LSB=4ms
----------------	----------------------------

8.31. TAP_DUR (2AH)

Table 82.TAP_DUR register

Default data: 0x24 Type: RW

Tap_shock[4]	Tap_shock[3]	Tap_shock[2]	Tap_shock[1]	Tap_shock[0]	Tap_dur[2]	Tap_dur[1]	Tap_dur[0]
--------------	--------------	--------------	--------------	--------------	------------	------------	------------

Table 83.TAP_DUR register description

Tap_shock[4:0]	range: 0-496ms LSB = 16ms
Tap_dur[2:0]	tap duration selects the length of the time window for the second shock 000: 50ms 001: 100ms 010: 150ms 011: 200ms 100: 250ms 101: 375ms 110: 500ms 111: 700ms

8.32. TAP_THS (2BH)

Table 84.TAP_THS register

Default data: 0x0A Type: RW

Tilt_time[2]	Tilt_time[1]	Tilt_time[0]	Tap_th [4]	Tap_th [3]	Tap_th [2]	Tap_th [1]	Tap_th [0]
--------------	--------------	--------------	------------	------------	------------	------------	------------

Table 85.TAP_THS register description

Tilt_time[2:0]	stable time for tilt detection LSB = 64 * 1/ODR
Tap_th [4:0]	threshold of tap interrupt=Tap_th*K(mg) K = 62.5(2g range) K = 125(4g range) K = 250(8g range) K = 500 (16g range)

8.33. ORIENT_HYST (2CH)

Table 86. ORIENT_HYST register

Default data: 0x18 Type: RW

Unused	Orient_hyst[2]	Orient_hyst[1]	Orient_hyst[0]	Orient_block[1]	Orient_block [0]	Orient_mode [1]	Orient_mode [0]
--------	----------------	----------------	----------------	-----------------	------------------	-----------------	-----------------

Table 87. ORIENT_HYST register description

Orient_hyst[2:0]	set the hysteresis of the orientation interrupt 1LSB = 62.5mg
Orient_block[1:0]	00: no blocking 01: z blocking 10: z blocking or slope in any axis > 0.2g 11: no blocking
Orient_mode [1:0]	00: symmetrical 01: high-asymmetrical 10: low-asymmetrical 11: symmetrical

8.34. Z_BLOCK (2DH)

Table 88. Z_BLOCK register

Default data: 0x88 Type: RW

Tilt_th[3]	Tilt_th[2]	Tilt_th[1]	Tilt_th[0]	Z_blocking[3]	Z_blocking[2]	Z_blocking[1]	Z_blocking[0]
------------	------------	------------	------------	---------------	---------------	---------------	---------------

Table 89. Z_BLOCK register description

Tilt_th[3:0]	set the tilt threshold 0-480mg with LSB=32mg
Z_blocking[3:0]	defines the blocking acc_z between 0g to 0.9375g 1LSB=62.5mg

8.35. RESET_STEP (2EH)

Table 90. RESET_STEP register

Default data: 0x00 Type: RW

Reset_steps	Unused	Unused	Unused	Unused	Unused	Unused	Unused
-------------	--------	--------	--------	--------	--------	--------	--------

Table 91. RESET_STEP register description

Reset_steps	write 1 to reset step counter
-------------	-------------------------------

8.36. STEP_FILTER (33H)

Table 92.STEP_FILTER register

Default data: 0x25 Type: RW

Step_en	Unused	Unused	Unused	Unused	Unused	Unused	Unused
---------	--------	--------	--------	--------	--------	--------	--------

Table 93.STEP_FILTER register description

Step_en	0: disable 1: enable step detect function
---------	--

8.37. SM_THRESHOLD (34H)

Table 94.SM_THRESHOLD register

Default data: 0x32 Type: RW

SM_threshold[7]	SM_threshold[6]	SM_threshold[5]	SM_threshold[4]	SM_threshold[3]	SM_threshold[2]	SM_threshold[1]	SM_threshold[0]
-----------------	-----------------	-----------------	-----------------	-----------------	-----------------	-----------------	-----------------

Table 95.SM_THRESHOLD register description

SM_threshold[7:0]	0-255 step
-------------------	------------

8.38. ACTIVE_DUR (38H)

Table 96.ACTIVE_DUR register

Default data: 0x00 Type: RW

Inactive_dur[3]	Inactive_dur[2]	Inactive_dur[1]	Inactive_dur[0]	Active_dur[3]	Active_dur[2]	Active_dur[1]	Active_dur[0]
-----------------	-----------------	-----------------	-----------------	---------------	---------------	---------------	---------------

Table 97.ACTIVE_DUR register description

Inactive_dur[3:0]	inactive duration time = (Inactive_dur + 1)* 1/ODR
Active_dur[3:0]	active duration time = (Active_dur + 1)* 1/ODR

8.39. ACTIVE_X_THS (39H)

Table 98.ACTIVE_X_THS register

Default data: 0x14 Type: RW

Active_x_th[7]	Active_x_th[6]	Active_x_th[5]	Active_x_th[4]	Active_x_th[3]	Active_x_th[2]	Active_x_th[1]	Active_x_th[0]
----------------	----------------	----------------	----------------	----------------	----------------	----------------	----------------

Table 99.ACTIVE_X_THS register description

Active_x_th[7:0]	X axis threshold of active/inactive interrupt=Active_th*K(mg) K = 3.91(2g range) K = 7.81(4g range) K = 15.625(8g range) K = 31.25(16g range)
------------------	---

8.40. ACTIVE_Y_THS (3AH)

Table 100.ACTIVE_Y_THS register

Default data: 0x14 Type: RW

Active_y_th[7]	Active_y_th[6]	Active_y_th[5]	Active_y_th[4]	Active_y_th[3]	Active_y_th[2]	Active_y_th[1]	Active_y_th[0]
----------------	----------------	----------------	----------------	----------------	----------------	----------------	----------------

Table 101.ACTIVE_Y_THS register description

Active_y_th[7:0]	Y axis threshold of active/inactive interrupt=Active_th*K(mg) K = 3.91(2g range) K = 7.81(4g range) K = 15.625(8g range) K = 31.25(16g range)
------------------	---

8.41. ACTIVE_Z_THS (3BH)

Table 102.ACTIVE_Z_THS register

Default data: 0x14 Type: RW

Active_z_th[7]	Active_z_th[6]	Active_z_th[5]	Active_z_th[4]	Active_z_th[3]	Active_z_th[2]	Active_z_th[1]	Active_z_th[0]
----------------	----------------	----------------	----------------	----------------	----------------	----------------	----------------

Table 103.ACTIVE_Z_THS register description

Active_z_th[7:0]	Z axis threshold of active/inactive interrupt=Active_th*K(mg) K = 3.91(2g range) K = 7.81(4g range) K = 15.625(8g range) K = 31.25(16g range)
------------------	---

9. Package information

9.1. Outline dimensions

The sensor housing is a standard LGA package. Its dimensions are the following:

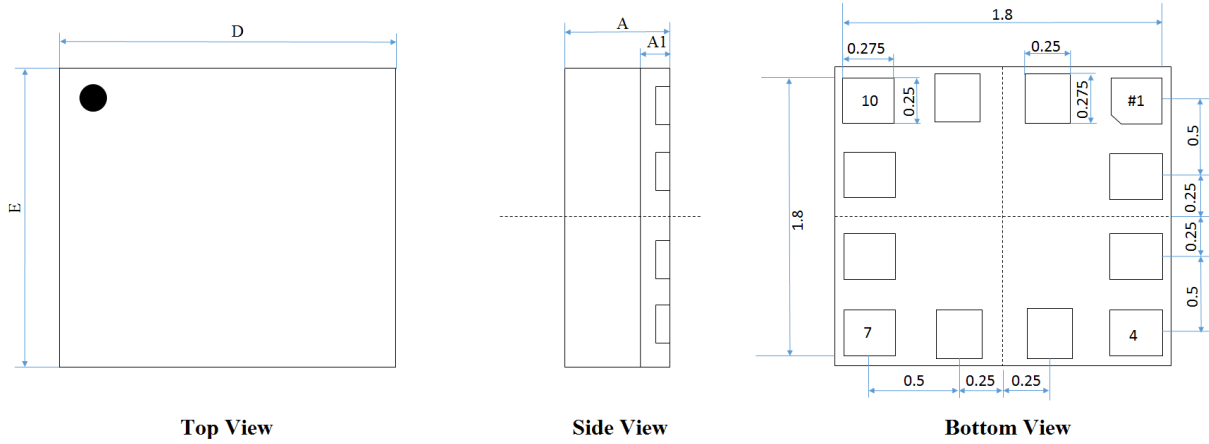

COMMON DIMENSIONS(MM)			
PKG.	W: VERYVERY THIN		
REF.	MIN	NOM	MAX
A	0.8	0.9	1
A1(SUBSTRATE)	0.2		
D	1.9	2	2.1
E	1.9	2	2.1

Figure 15 12Pin LGA Mechanical data and package dimensions

9.2. Landing pattern recommendation

For the design of the landing patterns, we recommend the following dimensioning:

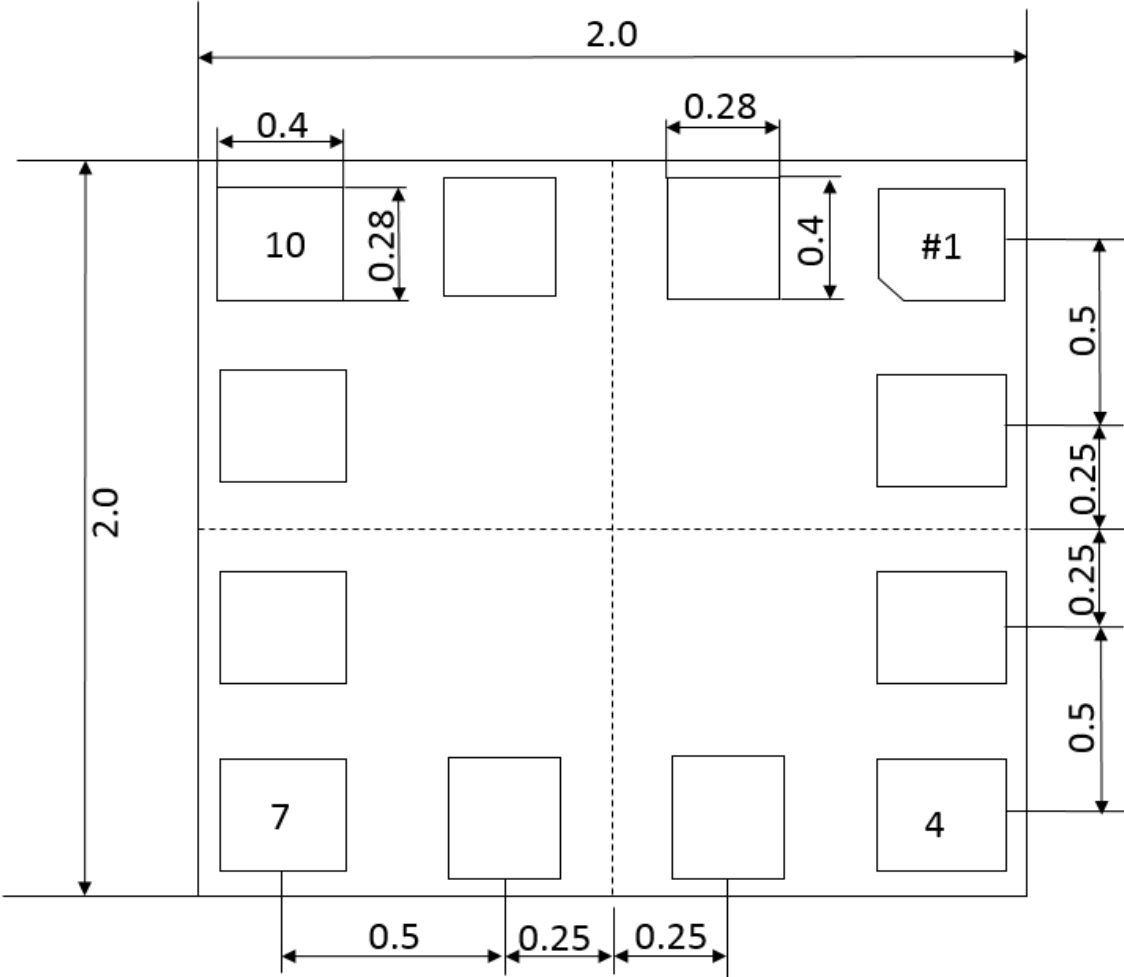

Bottom View

Figure 16 landing patterns; dimensions in mm

9.3. Soldering guidelines

The LGA package is qualified for soldering heat resistance according to IPC/JEDEC J-STD-020,

“Joint industry Standards: Moisture/Reflow Sensitivity Classification for non-hermetic Solid State surface Mount Devices”.

Shipping and handling is qualified according to IPC/JEDEC J-STD-033,

“Joint Industry Standard: Handling, Packing, Shipping and Use of Moisture/Reflow Sensitive Surface Mount Devices.

The sensor fulfils the lead-free soldering requirements of the above-mentioned IPC/JEDEC standard, i.e. reflow soldering with a peak temperature up to 260°C.

Profile Feature	Pb-Free Assembly
Preheat/Soak	
Temperature Min (T_{smin})	150 °C
Temperature Max (T_{smax})	200 °C
Time (t_s) from (T_{smin} to T_{smax})	60-120 seconds
Ramp-up rate (T_L to T_p)	3 °C/second max.
Liquidous temperature (T_L)	217 °C
Time (t_L) maintained above T_L	60-150 seconds
Peak package body temperature (T_p)	For users T_p must not exceed the Classification temp in Table below
Time (t_p)* within 5 °C of the specified classification temperature (T_c), see Figure 5-1.	30* seconds
Ramp-down rate (T_p to T_L)	6 °C/second max.
Time 25 °C to peak temperature	8 minutes max.

Package Thickness	Volume mm ³ <350	Volume mm ³ 350 - 2000	Volume mm ³ >2000
<1.6 mm	260 °C	260 °C	260 °C
1.6 mm - 2.5 mm	260 °C	250 °C	245 °C
>2.5 mm	250 °C	245 °C	245 °C

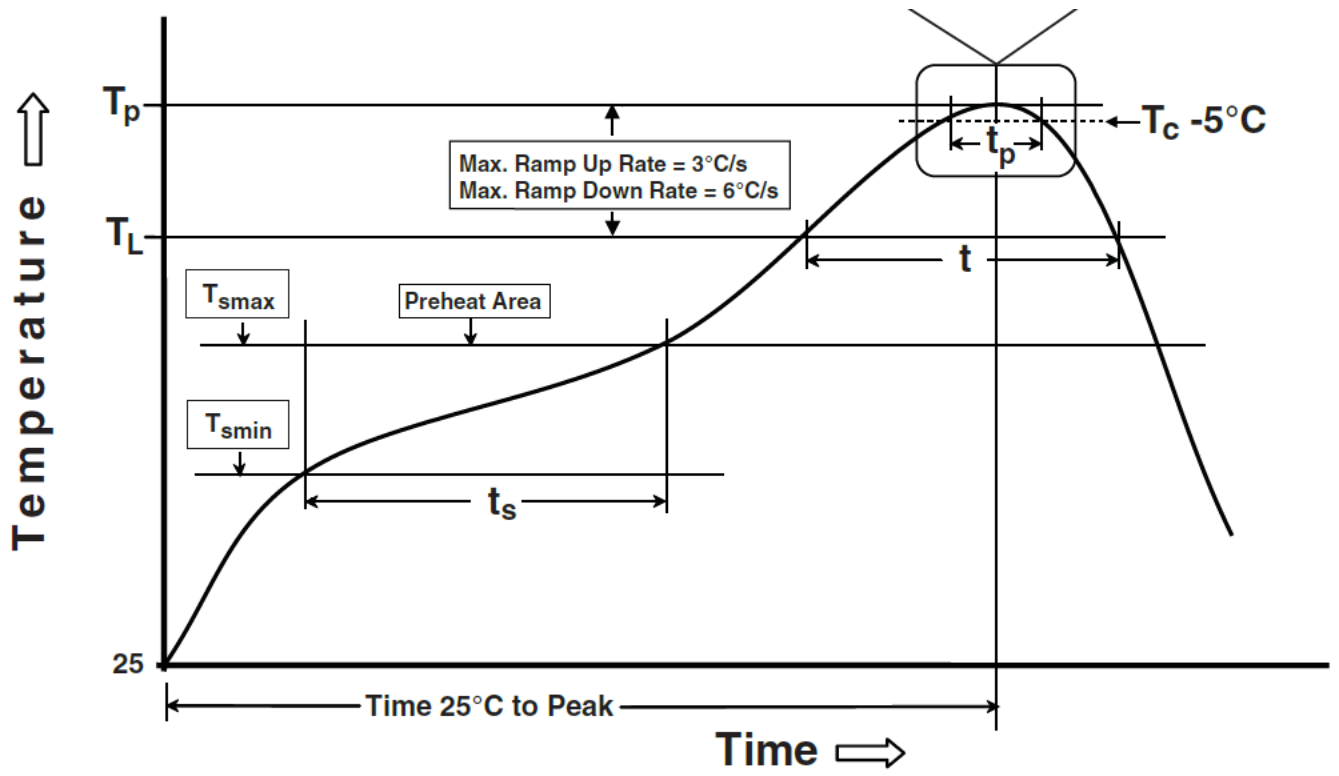

Figure 17 Soldering profile

9.4. Tape and reel specification

The da618G is shipped in a standard pizza box

The box dimension for 1 reel is: L x W x H = 355mm x 335mm x 50mm

The da618G quantity: 5000pcs per reel, please handle with care.

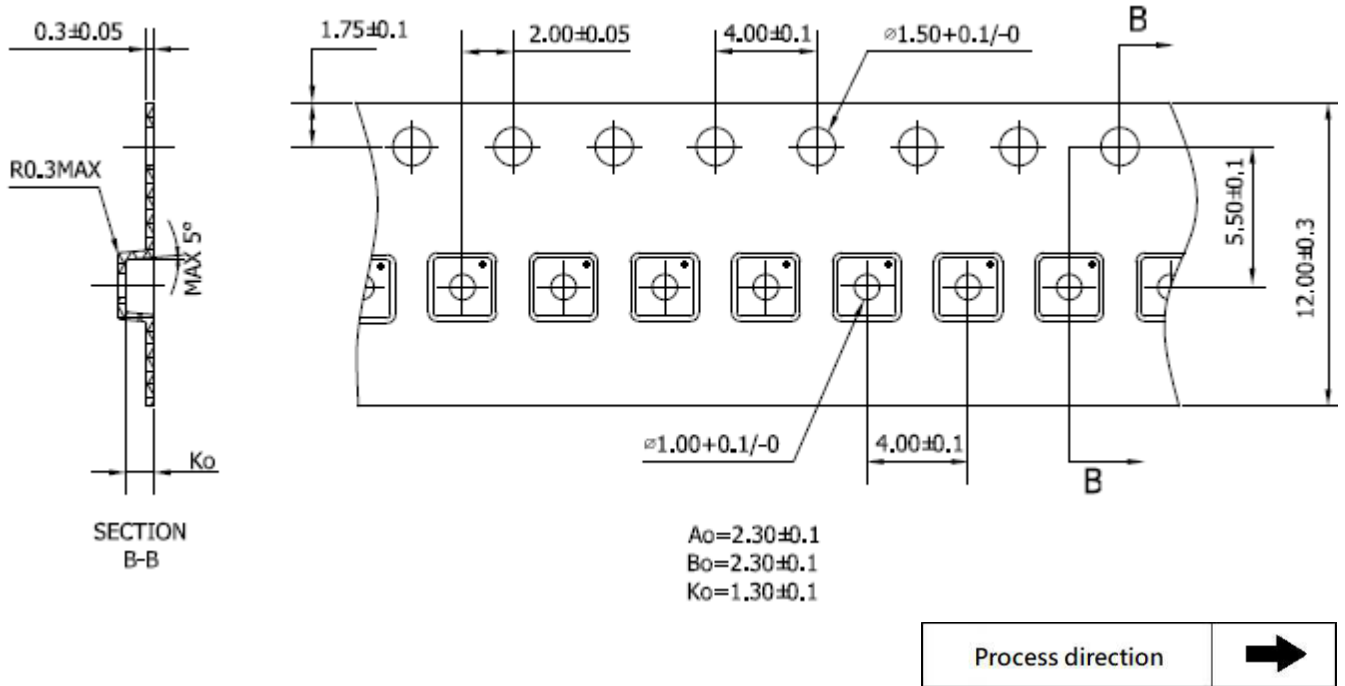

Figure 18 Tape and reel dimension in mm

10. Revision history

Table 104.Document revision history

Date	Revision	Changes
24-Oct.-2023	0.1	1. Initial release
14-Jun.-2024	0.2	1. Update suspend power consumption
04-Sep.-2024	0.3	1. Adjust the orientation of pin1 on the tape